

53-1002265-01
18 March 2011

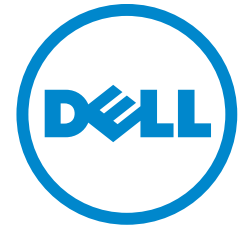

Dell PowerConnect B- Series T124X

Hardware Installation Guide

Information in this document is subject to change without notice.

© 2011 Dell Inc. All rights reserved.

Reproduction of these materials in any manner whatsoever without the written permission of Dell Inc. is strictly forbidden.

Trademarks used in this text: *Dell*, the *DELL* logo,, *Dell OpenManage* and *PowerConnect* are trademarks of Dell Inc.; *Microsoft*, *Windows*, *Windows Server*, *MS-DOS* and *Windows Vista* are either trademarks or registered trademarks of Microsoft Corporation in the United States and/or other countries.

Other trademarks and trade names may be used in this document to refer to either the entities claiming the marks and names or their products. Dell Inc. disclaims any proprietary interest in trademarks and trade names other than its own.

Regulatory Model Codes: Turbolron 24X

Contents

About This Document

In this chapter	vii
Audience	vii
Supported hardware and software	vii
Document conventions	vii
Text formatting	viii
Command syntax conventions	viii
Notes, cautions, and danger notices	viii
Related publications	ix
Getting technical help or reporting errors	ix
Contacting Dell	ix

Chapter 1

Product Overview

In this chapter	1
Product overview	1
Software features	1
Hardware features	1
Control features	2
Network interfaces	3
LEDs for network interfaces and power supplies	5
Power supplies	6

Chapter 2

Installing the PowerConnect B-Series TI24X

In this chapter	9
Unpacking a system	9
Package contents	9
General requirements	10
Summary of installation tasks	10
Installation precautions	11
General precautions	11
Lifting precautions	12
Power precautions	12
Preparing the installation site	15
Cabling infrastructure	15
Installation location	15

	Installing the device	15
	Desktop installation	15
	Rack mount installation	15
	Powering on the system	18
	Powering off the system	19
	Verifying proper operation	19
	Observing the power status LEDs	20
	Attaching a PC or terminal	20
Chapter 3	Connecting Network Devices and Checking Connectivity	
	In this chapter	23
	Assigning permanent passwords	23
	Recovering from a lost password	24
	Configuring IP addresses	25
	Devices running Layer 2 software	25
	Connecting network devices	26
	Connectors and cable specifications	26
	Connecting to Ethernet or fast Ethernet hubs	26
	Connecting to workstations, servers, or routers	27
	Connecting a network device to a fiber port	28
	Testing connectivity	29
	Pinging an IP address	29
	Observing LEDs	30
	Tracing a route	31
	Troubleshooting network connections	31
	Support for digital optical monitoring	31
Chapter 4	Managing the PowerConnect B-Series TI24X	
	In this chapter	33
	Managing temperature settings	33
	Using the temperature sensor	33
	Displaying the temperature	33
	Displaying temperature messages	34
	Changing the temperature warning level	34
	Changing the device temperature polling interval	34
	Removing MAC address entries	35
Chapter 5	Maintaining the PowerConnect B-Series TI24X Hardware	
	In this chapter	37
	Hardware maintenance schedule	37

Replacing a fiber optic module	37
Removing a fiber optic module	38
Installing a new fiber optic module.	39
Cabling a fiber optic module	39
Fiber-optic connectors	39
Replacing a power supply	39
Installation precautions and warnings	40
Determining which power supply failed	40
AC power supplies	41
Replacing the fan tray	45
Installation precautions and warnings	46
Removing the fan tray	46

Appendix A Hardware Specifications

Device specifications	50
Physical dimensions and weight.	50
Environmental considerations	50
Cooling	50
Regulatory compliance	51
Power source interruptions	52
Mean Time between Failure	52
Pinouts and signalling	52
Cable specifications.	53
PDU power cords(C13-C14).	55
Power supply specifications	55
Overview	55
Key features	55
Physical dimensions and weight.	56
Environmental considerations	56
Power supply consumption	57
Input connector and plug	57
Regulatory compliance	58
Safety warnings	58
Electrical specifications.	59

Appendix B Regulatory Approval and Statements

Agency approvals	61
Safety agency approvals	61
Electromagnetic emission	61
Immunity.	61
Regulatory statements	62
U.S.A..	62
Industry Canada statement.	62
Europe and Australia	62
Japan	62
Japan power cords.	63
Korea	63
China RoHS	64

Appendix C	Caution and Danger Notices	
	Cautions.....	65
	Danger.....	68

About This Document

In this chapter

- Audience. vii
- Supported hardware and software. vii
- Document conventions vii
- Related publications ix
- Getting technical help or reporting errors ix
- Contacting Dell ix

Audience

This manual is designed for system administrators with a working knowledge of Layer 2 and Layer 3 switching and routing.

You should be familiar with the following protocols if applicable to your network – IP, RIP, OSPF, IS-IS, BGP4, MBGP, IGMP, PIM, DVMRP, FSRP, VRRP, and VRRPE.

Supported hardware and software

The following hardware platform is supported by this release of this guide:

- PowerConnect B-Series T124X Series

Document conventions

This section describes text formatting conventions and important notice formats used in this document.

Text formatting

The narrative-text formatting conventions that are used are as follows:

bold text	Identifies command names Identifies the names of user-manipulated GUI elements Identifies keywords Identifies text to enter at the GUI or CLI
<i>italic text</i>	Provides emphasis Identifies variables Identifies document titles
code text	Identifies CLI output

For readability, command names in the narrative portions of this guide are presented in bold: for example, **show version**.

Command syntax conventions

Command syntax in this manual follows these conventions:

command and parameters	Commands and parameters are printed in bold.
[]	Optional parameter.
<i>variable</i>	Variables are printed in italics enclosed in angled brackets < >.
...	Repeat the previous element, for example “member[;member...]”
	Choose from one of the parameters.

Notes, cautions, and danger notices

The following notices and statements are used in this manual. They are listed below in order of increasing severity of potential hazards.

NOTE

A note provides a tip, guidance or advice, emphasizes important information, or provides a reference to related information.



CAUTION

A Caution statement alerts you to situations that can be potentially hazardous to you or cause damage to hardware, firmware, software, or data.



DANGER

A Danger statement indicates conditions or situations that can be potentially lethal or extremely hazardous to you. Safety labels are also attached directly to products to warn of these conditions or situations.

Related publications

The following *Dell* documents supplement the information in this guide:

- *PowerConnect B-Series TI24X Configuration Guide*
- *PowerConnect B-MLXe MIB Reference*

NOTE

For the latest edition of this document, which contains the most up-to-date information, refer to support.dell.com.

Getting technical help or reporting errors

Dell is committed to ensuring that your investment in our products remains cost-effective. If you need assistance or find errors in the manuals, contact Dell Technical Support. When contacting Dell Technical Support have the device configuration file and an output capture of show tech-support command available.

Contacting Dell

For customers in the United States, call 800-WWW.DELL (800.999.3355).

NOTE

If you do not have an active Internet connection, you can find contact information on your purchase invoice, packing slip, bill, or Dell product catalog.

Dell provides several online and telephone-based support and service options. Availability varies by country and product, and some services may not be available in your area. To contact Dell for sales, technical support, or customer service issues:

1. Visit <http://support.dell.com>.
2. Click your country or region at the bottom of the page. For a full listing of countries and regions, click All.
3. In the Support menu, click All Support.
4. Choose the method of contacting Dell that is convenient for you.

Product Overview

In this chapter

- [Product overview](#) 1
- [Software features](#) 1
- [Hardware features](#) 1

Product overview

PowerConnect B-Series TI24X provides high port density and 512 MB of DDR RAM when shipped from the factory. PowerConnect B-Series TI24X delivers a full complement of standards-based, feature-rich Layer 2 switching capability. The extensive feature set supports network requirements ranging from basic connectivity to multicast-enabled full streaming audio and video applications for converged services.

The PowerConnect B-Series TI24X supports:

- Twenty-four SFP+ ports at either 1 GbE or 10 GbE using the standard E1MG optics, as well as the new SFP+ 10GbE optics
- Four 10/100/1000 RJ-45 ports

Software features

Software features differ depending on the software version that is loaded on the device. When first shipped, the PowerConnect B-Series TI24X devices support full Layer 2 Switching.

For a complete list of software features supported on the PowerConnect, refer to the release notes or the *PowerConnect B-Series TI24X Configuration Guide*.

Hardware features

This section describes the physical characteristics of the PowerConnect B-Series TI24X models. For details about physical dimensions, power supply specifications, and pin-outs, refer to [Appendix A, "Hardware Specifications"](#).

1 Hardware features

Figure 1 shows the PowerConnect B-Series TI24X.

FIGURE 1 PowerConnect B-Series TI24X

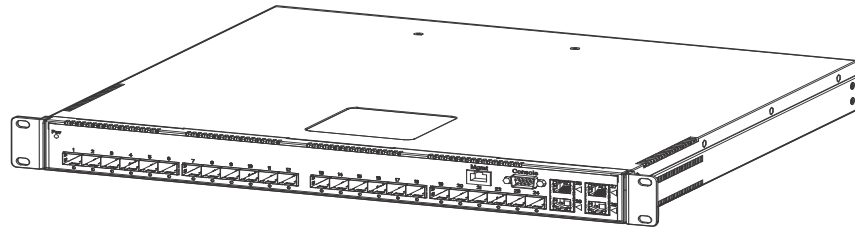

PowerConnect B-Series TI24X contains the following ports:

- Twenty-four (24) SFP+ 10 Gigabit and Gigabit Ethernet fiber ports
- Four (4) 10/100/1000 Mbps copper ports, supporting 100Base-TX and 1000Base-T RJ-45 connectors

Control features

PowerConnect B-Series TI24X front panel has the following control features:

- Serial management interface-DB-9 connector interface (Console Port)
- 10/100/1000 RJ-45 Management Port

FIGURE 2 Console and management ports

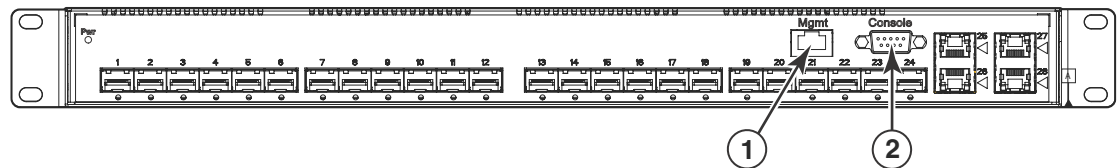

1 Management Port

2 Console Port

Serial management interface (Console port)

The serial management interface (port labeled Console) enables you to configure and manage the device using a third-party terminal emulation application on a directly-connected PC, straight-through EIA or TIA DB-9 serial cable (M/F) is included. The console port is located in the upper right of the front panel.

Management port

The Management port provides connectivity to your existing management network through 10/100/1000 copper ports that uses auto-sensing and auto-negotiating to determine the speed (10 Mbps, 100 Mbps, or 1000 Mbps) and mode (full-duplex or half-duplex) of the port at the other end of the link, and adjusts port speed accordingly. The Management port on the PowerConnect B-Series TI24X supports RJ-45 copper connectors, auto MDI or MDIX detection, and has an RJ-45 unshielded twisted pair (UTP) connector.

NOTE

This port interfaces with the CPU only and not the data plane.

Network interfaces

[Table 1](#) describes the network interfaces supported on PowerConnect B-Series TI24X devices. For network interface specifications, refer to [Table 12](#) on page 54.

TABLE 1 Optics for Network Interfaces

Interface	Show Media Description
1000Base-BX-D	M-GBXD
1000Base-BX-U	M-GBXU
1000Base-LHA	M-LHA
1000Base-LX	M-LX
1000Base-SX	M-SX
10GBase-LR	XG-LR
10GBase-SR	XG-SR

Viewing the media types installed in the ports

The show media command displays the types of media (copper or fiber) installed in the ports. The following example is **show media** output.

```
PowerConnect# show media
Port 1: Type : 10G XG-SR(SFP+)
Vendor: Brocade Version: 1
Part# : PLRXPLSCS4371 Serial#: C833UQ06H
Port 2: Type : EMPTY
Port 3: Type : EMPTY
Port 4: Type : EMPTY
Port 5: Type : EMPTY
Port 6: Type : 10G XG-SR(SFP+)
Vendor: Brocade Version: 1
Part# : PLRXPLSCS4371 Serial#: C847UQ04C
Port 7: Type : 10G XG-SR(SFP+)
Vendor: Brocade Version: 1
Part# : PLRXPLSCS4371 Serial#: C847UQ04H
Port 8: Type : EMPTY
Port 9: Type : EMPTY
Port 10: Type : EMPTY
Port 11: Type : EMPTY
Port 12: Type : EMPTY
```

1 Hardware features

Port 13: Type : 10G XG-SR(SFP+)
Vendor: Brocade Version: 1
Part# : PLRXPLSCS4371 Serial#: C847UQ04T
Port 14: Type : 10G XG-SR(SFP+)
Vendor: Brocade Version: 1
Part# : PLRXPLSCS4371 Serial#: C847UQ04R
Port 15: Type : 10G XG-SR(SFP+)
Vendor: Brocade Version: 1
Part# : PLRXPLSCS4371 Serial#: C847UQ050
Port 16: Type : 10G XG-SR(SFP+)
Vendor: Brocade Version: 1
Part# : PLRXPLSCS4371 Serial#: C847UQ059
Port 17: Type : EMPTY
Port 18: Type : EMPTY
Port 19: Type : 10G XG-SR(SFP+)
Vendor: Brocade Version: 1
Part# : PLRXPLSCS4371 Serial#: C847UQ04K
Port 20: Type : 10G XG-SR(SFP+)
Vendor: Brocade Version: 1
Part# : PLRXPLSCS4371 Serial#: C833UQ068
Port 21: Type : EMPTY
Port 22: Type : EMPTY
Port 23: Type : EMPTY
Port 24: Type : EMPTY
Port 25: Type : 1G M-C (Gig-Copper)
Port 26: Type : 1G M-C (Gig-Copper)
Port 27: Type : 1G M-C (Gig-Copper)
Port 28: Type : 1G M-C (Gig-Copper)

10 Gbps ports

Ports 1 - 24 support 1-GbE SFP transceivers and 10-GbE SFP and SFP+ transceivers listed in [Table 1](#). [Figure 3](#) shows ports 1 - 24.

FIGURE 3 24 10-GbE ports

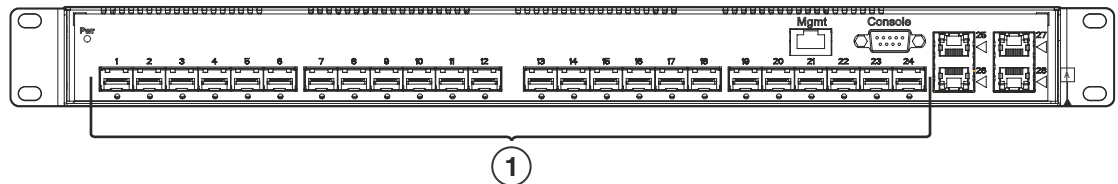

1 10-GbE Ports

Four 10/100/1000 Mbps ports

The ports 25~28 are 10/100/1000 copper ports that use auto-sensing and auto-negotiating to determine the speed (10 Mbps, 100 Mbps, or 1000 Mbps) and mode (full-duplex or half-duplex) of the port at the other end of the link, and adjust port speed accordingly.

10/100/1000 ports on the PowerConnect B-Series TI24X support RJ-45 copper connectors. The output of the **show media** command displays **C** next to the ports that have copper connectors installed.

Gigabit copper ports on the PowerConnect B-Series TI24X support auto MDI or MDIX detection. For more information about this feature, refer to "Configuring MDI/MDIX" in the *PowerConnect B-Series TI24X Configuration Guide*.

LEDs for network interfaces and power supplies

The fiber and copper ports on PowerConnect B-Series TI24X provide status information through the LEDs listed in [Table 2](#). The LEDs for network interfaces and power supplies are:

- 24 10-Gbps fiber ports (1~24 port) have LEDs located under each of them.
- Four 10/100/1000 copper ports (25~28) have Link and Activity LEDs to indicate port status.
- The Management port has a Link LED and Activity LED to indicate port status. The Link LED is on the left of the copper connector and the Activity LED is on the right.
- The System power on LED is on the left side of the front panel.
- The dual power supply 1 and 2 LEDs are on the front panel of the power supply (when you are facing the rear of the device).

TABLE 2 LEDs

LEDs	Position	State	Meaning
10Gbps Port LEDs			
LNK or ACT	Located under the 10-GbE ports	On	The port is connected.
		Off	No fiber port connection exists or the link is down.
		Blinking	Traffic is begin transmitted or received on the fiber port.
10/100/1000 Copper Port LEDs			
Lnk	This is the left LED on RJ45	On	The port is connected.
		Off	No copper port connection exists or the link is down.
Act	This is the right LED on RJ45	On or Blinking	Traffic is being transmitted or received on the copper port.
		Off	No traffic is being transmitted or received on the copper port.
Management Port LEDs			
Lnk	This is the left LED on RJ45	On	The port is connected.
		Off	No copper port connection exists or the link is down.
Act	This is the right LED on RJ45	On or Blinking	Traffic is being transmitted or received on the copper port.
		Off	No traffic is being transmitted or received on the copper port.
System Power and Power Supply LEDs			

1 Hardware features

TABLE 2 LEDs (Continued)

LEDs	Position	State	Meaning
Power	On the upper left side of the front panel (when facing the front of the device)	On	The device is powered on and has enough power to operate.
		Off	The device is not powered on, or has been powered on but does not have sufficient power to operate.
AC OK	Upper center of power supply's front panel (when facing the rear of the device)	On	Indicated power supply is installed and is functioning normally. NOTE: Power supply 1 is located in the right-hand bay and power supply 2 in the left-hand bay (when facing the rear of the device).
		Off	Power supply is not installed or is not providing power.

Power supplies

Each PowerConnect B-Series T124X device comes with dual alternating-current (AC) power supplies (RPS-T124X). Power supplies are hot-swappable. [Figure 4](#) shows the front panel of the AC power supplies used in the PowerConnect B-Series T124X (at the rear of the device).

FIGURE 4 AC power supply front panel

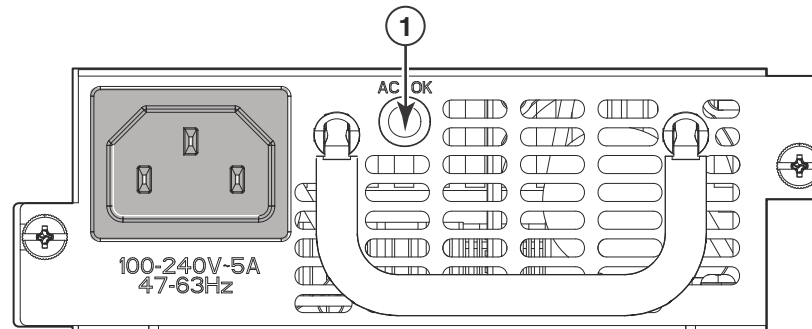

1 AC LED

The power supplies are auto-sensing and auto-switching, and provide up to 300 watts of total output power, having a universal input (100 VAC to 240 VAC) and 12 VDC regulated output.

Power supplies can be swapped in or out of the device while the device is running, and without opening the device. You can remove one of the supplies without interrupting operation because the remaining power supply provides enough power for all of the ports.

For power supply hardware specifications, refer to [“Power supply specifications”](#) on page 55.

**CAUTION**

Disconnect the power supply cable from the power source (outlet) before you install it in or remove it from the device. Failure to do this can result in damage to the power supply or the device, or both (the device can be running while a power supply is being installed or removed, but the power supply itself should not be connected to a power source).

1 Hardware features

Installing the PowerConnect B-Series TI24X

In this chapter

- Unpacking a system 9
- Summary of installation tasks 10
- Installation precautions 11
- Preparing the installation site..... 15
- Installing the device 15
- Powering on the system 18
- Verifying proper operation..... 19
- Attaching a PC or terminal 20

Unpacking a system



DANGER

The procedures in this manual are intended for qualified service personnel.

Information about configuring IP addresses and connecting network devices is in the [Chapter 3, “Connecting Network Devices and Checking Connectivity”](#).

Dell PowerConnect systems ship with all of the items listed below. Please review the list and verify the contents. If any items are missing, please contact the place of purchase.

Package contents

Verify the package contents listed below:

- Dell PowerConnect B-Series TI24X device with dual AC power supplies installed
- AC PDU power cords (C13-C14)
- Document kit
- Retainer nuts and screws
- Rubber feet
- Rack mount kit (includes rack mount brackets, retainer nuts and screws)

General requirements

To manage the system, you will need the following items for serial connection to a Layer 2 or Layer 3 switch:

- A management station, such as a PC running a terminal emulation application.
- A straight-through EIA or TIA DB-9 serial cable (F/F). If you prefer to build your own cable, refer to the pinout information in [“Attaching a PC or terminal”](#) on page 20.
- Use the serial connection to perform basic configuration tasks, such as assigning an IP address and network mask. This information is required to manage the system using the Brocade Network Advisor or using the CLI through Telnet.

Summary of installation tasks

Follow the steps listed below to install your PowerConnect B-Series TI24X device. Details for each of these steps are provided in this chapter and in the following chapter.

TABLE 3 Summary of installation tasks

Task No.	Task	Where to Find More Information
1	Ensure that the physical environment where the device will be installed has the proper cabling and ventilation.	“Preparing the installation site” on page 15
2	Install the Dell PowerConnect device on a desktop or in an equipment rack. Devices may also be wall-mounted.	“Installing the device” on page 15
3	When the device is installed, plug the PDU power cords (C13-C14) into a nearby power source that adheres to the regulatory requirements outlined in this manual.	“Powering on the system” on page 18
4	Verify that power LED is on after the system is powered-on.	“Verifying proper operation” on page 19
5	Attach a terminal or PC to the Dell PowerConnect device. This enables you to configure the device through the Command Line Interface (CLI).	“Attaching a PC or terminal” on page 20
6	No default password is assigned to the CLI. For additional access security, assign a password.	“Assigning permanent passwords” on page 23
7	Before attaching equipment to the device, you must configure an interface IP address to the subnet on which it will be located. Initial IP address configuration is performed using the CLI with a direct serial connection.	“Configuring IP addresses” on page 25
8	Once you power-on the device and assign IP addresses, the system is ready to accept network equipment.	“Connecting network devices” on page 26
9	Test IP connectivity by pinging other devices and tracing routes.	“Testing connectivity” on page 29
10	Continue configuration using the CLI. You also can use Brocade Network Advisor to manage the device.	<i>PowerConnect B-Series TI24X Configuration Guide</i>
11	Secure access to the device.	<i>PowerConnect B-Series TI24X Configuration Guide</i>

Installation precautions

Follow these precautions when installing a Dell PowerConnect device.

General precautions



CAUTION

Do not install the device in an environment where the operating ambient temperature might exceed 40° C (104° F).



CAUTION

Make sure that air flow around the front, sides, and back of the device is not restricted.



CAUTION

Never leave tools inside the device.



CAUTION

Use the erase startup-config command only for new systems. If you enter this command on a system you have already configured, the command erases the configuration. If you accidentally do erase the configuration on a configured system, enter the write memory command to save the running configuration to the startupconfig file.



CAUTION

Changes or modifications made to this device that are not expressly approved by the party responsible for compliance could void the user's authority to operate the equipment.



DANGER

All fiber-optic interfaces use Class 1 lasers.

Lifting precautions



DANGER

Make sure the rack or cabinet housing the device is adequately secured to prevent it from becoming unstable or falling over.



DANGER

Do not use the handles on the power supply units to lift or carry a Dell PowerConnect device.



DANGER

Mount the devices you install in a rack or cabinet as low as possible. Place the heaviest device at the bottom and progressively place lighter devices above.

Power precautions

The following precautions apply to PowerConnect B-Series T124X devices:



CAUTION

Use a separate branch circuit for each AC power cords , to provide redundancy in case one of the circuits fails.



CAUTION

Ensure that the device does not overload the power circuits, wiring, and over-current protection. To determine the possibility of overloading the supply circuits, add the ampere (amp) ratings of all devices installed on the same circuit as the device. Compare this total with the rating limit for the circuit. The maximum ampere ratings are usually printed on the devices near the input power connectors.



CAUTION

Make sure you insert the power supply right-side up. It is possible to insert the supply upside down, although the supply will not engage with the power backplane cotter pin when plugged upside down. The label of the power supply is on the top when you plug in the power supply right-side up when the power connector is on the left and the fan vent is on the right.

**CAUTION**

Remove the power cords from a power supply before you install it in or remove it from the device. Otherwise, the power supply or the device could be damaged (the device can be running while a power supply is being installed or removed, but the power supply itself should not be connected to a power source).

**CAUTION**

The PowerConnect B-Series T124X power supply is designed exclusively for use with PowerConnect B-Series T124X devices. Installing the power supply in a device other than the PowerConnect B-Series T124X will cause extensive damage to your equipment.

2 Installation precautions



CAUTION

Risk of explosion if battery is replaced by an incorrect type. Replace the battery only with the same or equivalent type recommended by the manufacturer. Dispose of used battery according to the instructions.



DANGER

Disconnect the power cords from all power sources to completely remove power from the device.



DANGER

Make sure to choose the appropriate circuit device depending on the number of AC power supplies installed in the device. The minimum current draw for the system is one AC power supply.



DANGER

Power supplies are hot swappable. However, Dell recommends that you disconnect the power supply from AC power before installing or removing the supply. The device can be running while a power supply is being installed or removed, but the power supply itself should not be connected to a power source. Otherwise, you could be injured or the power supply or other parts of the device could be damaged.



DANGER

Make sure that the power source circuits are properly grounded, then use the power cords supplied with the device to connect it to the power source.



DANGER

If the installation requires a different power cord than the one supplied with the device, make sure you use a power cord displaying the mark of the safety agency that defines the regulations for power cords in your country. The mark is your assurance that the power cords can be used safely with the device.



DANGER

For safety reasons, the ESD wrist strap should contain a series 1 MB ohm resistor.

Preparing the installation site

Cabling infrastructure

Ensure that the proper cabling is installed in the site. Refer to “[Device specifications](#)” on page 50 for a summary of supported cabling types and their specifications.

Installation location

Before installing the device, plan its location and orientation relative to other devices and equipment. Allow at least 3 inches of space at the front of the device for the twisted-pair, fiber-optic, and power cabling to ensure there is no airflow blockage or interference of cable routing. Also, allow a minimum of 3 inches of space between the sides and the back of the device and walls or other obstructions.

Installing the device

You can install Dell PowerConnect devices on a desktop or in an equipment rack.



DANGER

Make sure the rack or cabinet housing the device is adequately secured to prevent it from becoming unstable or falling over.



DANGER

Mount devices in a rack or cabinet as low as possible. Place the heaviest device at the bottom and progressively lighter devices above.

Desktop installation

Follow the steps for desktop installation.

1. Set the device on a flat desktop, table, or shelf. Make sure that adequate ventilation is provided for the system. A 3 in. clearance is recommended on each side.
2. Proceed to “[Powering on the system](#)” on page 18.

Rack mount installation

For rack mount installation, the Dell PowerConnect B-Series TI24X supports the use of a two post Telco equipment rack and four post equipment rack.

NOTE

For additional support under the stack of switches. Use Dell 1U shelf, Dell p/n:G118R.

2 Installing the device

A rack mount kit with short mounting brackets ships with the device.

In addition to the rack mount kit, you will need the following tools for installation:

- #2 Phillips-head screwdriver
- Four 12-24 screws to mount the PowerConnect device in the two post equipment rack.
- Four 10-32 screws to mount the PowerConnect device in the four post equipment rack.



DANGER

Make sure the rack or cabinet housing the device is adequately secured to prevent it from becoming unstable or falling over.



DANGER

Mount the devices you install in a rack or cabinet as low as possible. Place the heaviest device at the bottom and progressively place lighter devices above.



DANGER

Mechanical Loading - Mounting of the equipment in the rack should be such that a hazardous condition is not achieved due to uneven mechanical loading.



DANGER

Elevated Operating Ambient - If installed in a closed or multi-unit rack assembly, the operating ambient temperature of the rack environment may be greater than room ambient. Therefore, consideration should be given to installing the equipment in an environment compatible with the maximum ambient temperature (T_{ma}) specified by the manufacturer.



DANGER

Reduced Air Flow - Installation of the equipment in a rack should be such that the amount of air flow required for safe operation of the equipment is not compromised.



DANGER

Circuit Overloading - Consideration should be given to the connection of the equipment to the supply circuit and the effect that overloading of the circuits might have on overcurrent protection and supply wiring. Appropriate consideration of equipment nameplate ratings should be used when addressing this concern.

**DANGER**

Reliable Earthing - Reliable earthing of rack-mounted equipment should be maintained. Particular attention should be given to supply connections other than direct connections to the branch circuit (e.g. use of power strips).

Follow the steps to install the rack mount brackets and mount the device in a rack.

1. Remove the rack mount kit from the shipping carton. The kit contains two mounting brackets.
2. Place the Network switch on a hard flat surface with the front panel facing you.
3. Attach a rack-mount bracket to one side of the Network switch with the supplied screws. Then attach the other bracket to the other side.
4. Attach retainer nuts into the non threaded holes in the four post rack. Use 10-32 screws to attach brackets to the rack.

**DANGER**

Make sure you use the screws supplied with the mounting brackets. Using the wrong screws could damage the PowerConnect B-Series TI24X and would invalidate your warranty.

Figure 5 shows how to attach the short mounting brackets.

FIGURE 5 Attaching the short mounting brackets

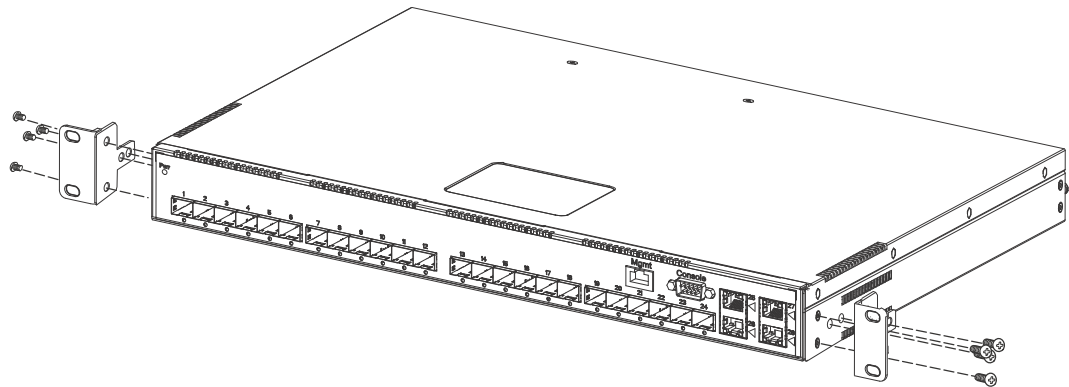

Mount the device in the rack as illustrated in Figure 6.

FIGURE 6 Installing the device in a rack

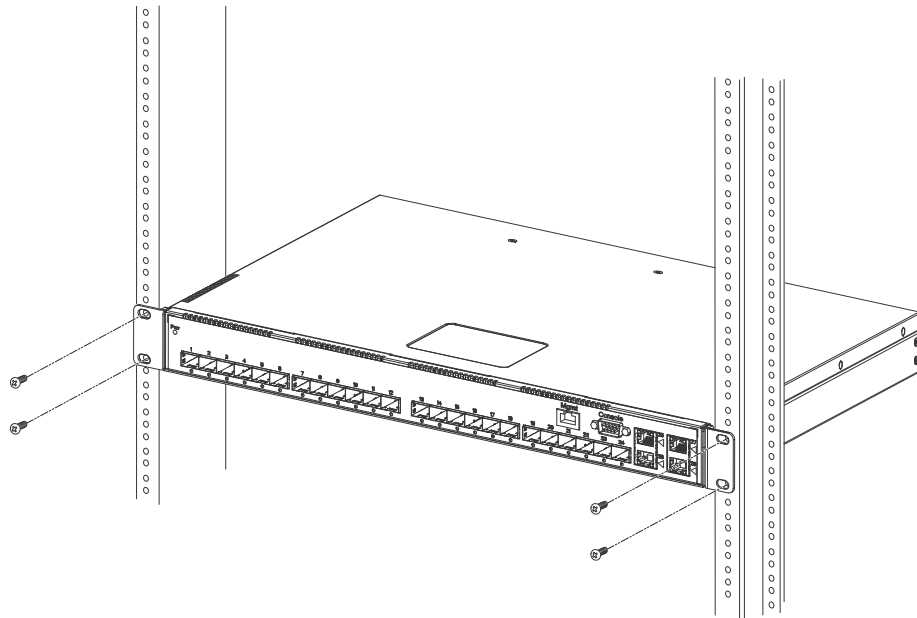

5. Proceed to [“Powering on the system”](#).

Powering on the system

Note the following before powering on the system:

- The AC outlet should be installed near the equipment and should be easily accessible.
- Get the appropriate cable for the AC outlet.
- If your installation requires a different PDU power cords (C13-C14) than that supplied with the device, make sure you obtain a PDU power cords (C13-C14) displaying the mark of the safety agency that defines the regulations for PDU power cords(C13-C14) in your country. The mark is your assurance that the PDU power cords (C13-C14) can be used safely with the device.
- Ensure that all power supplies are fully and properly inserted.
- Remove the PDU power cords (C13-C14) from the shipping package.
- Attach the AC PDU power cords (C13-C14) to the AC connector on the rear panel as shown in [Figure 7](#).

NOTE

Align the locating notch on the underside of the AC PDU power cords (C13-C14) before inserting.

- Insert the PDU power cords (C13-C14) plug into a properly grounded 115V or 120V electrical outlet.

FIGURE 7 Attaching the AC PDU power cords (C13-C14)

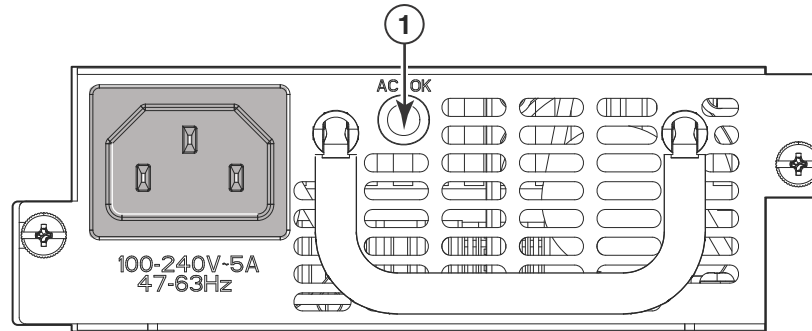

- Repeat this procedure for the second power supply.
- Verify the device is working properly (refer to [“Verifying proper operation”](#)).

Powering off the system

To turn an AC system OFF:

- Unplug the PDU power cords(C13-C14) from the power source.

Verifying proper operation

After you have installed any additional power supplies and powered on the system, verify that the device is working properly.

1. Verify that the LEDs on the power supply and system power LED are solid green.
2. Verify proper operation by observing the LEDs on the front panel.

10G port LEDs should be lit while the device performs diagnostics. After the diagnostics are complete, the LEDs will be dark except for those that are attached by cables to other devices.

If the links on these cables are good and the connected device is powered on, the link LEDs will light. [Table 4](#) provides more details on specific LED conditions after system start-up.

Observing the power status LEDs

Table 4 lists the device LEDs that show power status.

TABLE 4 Power LEDs

LEDs	Position	State	Meaning
Pwr (Power)	Left-most LED on the front panel	On	The device is powered on and has enough power to operate.
		Off	The device is not powered on, or has been powered on but does not have sufficient power to operate.
AC OK	On power supply 1 front panel	On	Power supply 1 is installed and is functioning normally. Power supply 1 is located in the right-hand bay (when you are facing the rear of the device).
		Off	Power supply 1 is not installed or is not providing power.
AC OK	On power supply 2 front panel	On	Power supply 2 is installed and is functioning normally. Power supply 2 is located in the left-hand bay (when you are facing the rear of the device).
		Off	Power supply 2 is not providing power.

The software regularly polls the hardware for power status information. You can display the status information from any management session using the **show chassis** CLI command. In addition, the software automatically generates a Syslog message and SNMP trap if a status change occurs.

Attaching a PC or terminal

To assign an IP address, you must have access to the **Command Line Interface (CLI)**. The CLI is a text-based interface that can be accessed through a direct serial connection to the device or through Telnet connections.

You will need to assign an IP address using the CLI. You can access the CLI by attaching management station through a serial cable to the Console port. After you assign an IP address, you can access the system through Telnet or Brocade Network Advisor.

Follow the steps to attach a management station using the serial port.

1. Use a straight-through cable to connect a PC or terminal to the male DB-9 serial port connector.

NOTE

You need to run a terminal emulation program on the PC.

2. Open the terminal emulation program and set the session parameters as follows:
 - Baud: 9600 bps
 - Data bits: 8
 - Parity: None
 - Stop bits: 1

- Flow control: None

When you establish the serial connection to the system, press Enter to display the CLI prompt in the terminal emulation window. For example,

```
PowerConnect>
```

When you see one of these prompts, you are connected to the system and can proceed to [“Assigning permanent passwords”](#) on page 23.

You can customize the prompt by changing the system name. Refer to the *PowerConnect B-Series T124X Configuration Guide*.

If you do not see a prompt:

- Make sure the cable is securely connected to your PC and to the *PowerConnect B-Series T124X* device.
- Check the settings in your terminal emulation program. In addition to the session settings listed above, make sure the terminal emulation session is running on the same serial port you attached to the *PowerConnect B-Series T124X* device.

The EIA or TIA 232 serial communication port serves as a connection point for management by a PC or SNMP workstation. *Dell* switches and Layer 3 Switches come with a standard male DB-9 connector, shown in [Figure 8](#).

FIGURE 8 Serial port pin and signalling details

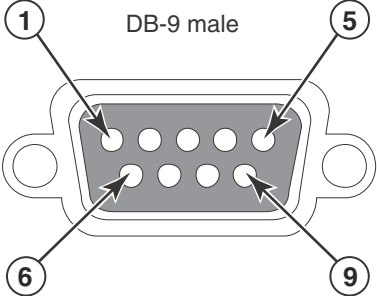
Pin Assignment	Pin Number	Switch Signal
	1	Reserved
	2	TXD (output)
	3	RXD (input)
	4	Reserved
	5	GND
	6	Reserved
	7	CTS (input)
	8	RTS (output)
	9	Reserved

Most PC serial ports also require a cable with a female DB-9 connector.

Terminal connections will vary, requiring either a DB-9 or DB-25 connector, male or female.

Serial cable options between a *Dell* switch or router and a PC or terminal are shown in [Figure 9](#).

2 Attaching a PC or terminal

FIGURE 9 Serial port pin assignments showing cable connection options to a terminal or PC

DB-9 to DB-9 Female Switch			Terminal or PC	DB-9 to DB-25 Female Switch			Terminal or PC
1	Reserved		1	1	Reserved		8
2	→		2	2	→		3
3	←		3	3	←		2
4	Reserved		4	4	Reserved		20
5	→		5	5	→		7
6	Reserved		6	6	Reserved		6
7	←		7	7	←		4
8	→		8	8	→		5
9	Reserved		9	9	Reserved		22

NOTE

As indicated in [Figure 8](#) and [Figure 9](#), some of the wires should not be connected. If you do connect the wires that are labeled "Reserved", you might get unexpected results with some terminals.

Connecting Network Devices and Checking Connectivity

In this chapter

- Assigning permanent passwords 23
- Configuring IP addresses 25
- Connecting network devices 26
- Testing connectivity 29
- Troubleshooting network connections 31

Assigning permanent passwords



DANGER

The procedures in this manual are intended for qualified service personnel.

This chapter provides the details for connecting network devices and checking network connectivity.

By default, the CLI is not protected by passwords. To secure CLI access, *Dell* strongly recommends assigning passwords.

NOTE

You can assign passwords using *Brocade Network Advisor* if an enable password for a Super User has been configured on the device.

The CLI contains the following access levels:

- **User EXEC**—The level you enter when you first start a CLI session. At this level, you can view some system information but you cannot configure system or port parameters.
- **Privileged EXEC**—Also called the Enable level, and can be secured by a password. At this level, you can perform tasks such as manage files on the flash module, save the system configuration to flash, and clear caches.
- **CONFIG**—This level lets you configure the system IP address, and switching and routing features. To access the CONFIG mode, you must already be logged into the Privileged level of the EXEC mode (the Enable level).

You can set the following levels of Enable passwords:

- **Super User** - Allows complete read-and-write access to the system. This is generally for system administrators and is the only password level that allows you to configure passwords.

NOTE

You must set a super user password before you can set other types of passwords.

3 Assigning permanent passwords

- **Port Configuration** - Allows read-and-write access for specific ports but not for global (system-wide) parameters.
- **Read Only** - Allows access to the Privileged EXEC mode and CONFIG mode but only with read access.

Follow the steps to set passwords.

1. At the opening CLI prompt, enter the following command to change to the Privileged level of the EXEC mode.

```
PowerConnect> enable
```

2. Access the CONFIG level of the CLI by entering the following command.

```
PowerConnect# configure terminal
PowerConnect(config)#
```

3. Enter the following command to set the super-user password.

```
PowerConnect(config)# enable super-user-password <text>
```

NOTE

You must set the super user password before you can set other types of passwords.

4. Enter the following commands to set the port configuration and read-only passwords.

```
PowerConnect(config)# enable port-config-password <text>
PowerConnect(config)# enable read-only-password <text>
```

NOTE

If you forget your super user password, refer to [“Recovering from a lost password”](#).

Syntax: enable super-user-password | read-only-password | port-config-password <text>

Passwords can be up to 32 characters long.

Recovering from a lost password

By default, the CLI does not require passwords. However, if someone has configured a password for the device but the password has been lost, you can regain super-user access to the device using the following procedure.

NOTE

Recovery from a lost password requires direct access to the serial port and a system reset.

Follow the steps to recover from a lost password.

1. Start a CLI session over the serial interface to thePowerConnect device.
2. Reboot the device.
3. While the system is booting, before the initial system prompt appears, enter **b** to enter the boot monitor mode.
4. Enter **no password** at the prompt. (You cannot abbreviate this command.)
5. Enter **boot system flash primary** at the prompt. This command causes the device to bypass the system password check.
6. After the console prompt reappears, assign a new password.

Configuring IP addresses

You must configure at least one IP address using the serial connection to the CLI before you can manage the system using the other management interfaces. In addition, *Dell* routers require an IP subnet address for the subnet in which you plan to place them in your network.

Dell PowerConnect devices support both classical IP network masks (Class A, B, and C subnet masks, and so on) and Classless Interdomain Routing (CIDR) and network prefix masks as follows:

- To enter a classical network mask, enter the mask in IP address format. For example, enter, "209.157.22.99 255.255.255.0" for an IP address with a Class-C subnet mask.
- To enter a prefix number for a network mask, enter a forward slash (/) and the number of bits in the mask immediately after the IP address. For example, enter, "209.157.22.99/24" for an IP address that has a network mask with 24 significant ("mask") bits.

By default, the CLI displays network masks in classical IP address format (example: 255.255.255.0). You can change the display to the prefix format. Refer to the *PowerConnect B-Series T124X Configuration Guide*.

Devices running Layer 2 software

Follow the steps to configure an IP address on a device running Layer 2 software.

1. At the opening CLI prompt, enter **enable**.

```
PowerConnect> enable
```

2. Enter the following command at the Privileged EXEC level prompt (for example, PowerConnect Switch#), then press Enter. This command erases the factory test configuration if still present.

```
PowerConnect# erase startup-config
```



CAUTION

Use the erase startup-config command only for new systems. If you enter this command on a system you have already configured, the command erases the configuration. If you accidentally do erase the configuration on a configured system, enter the write memory command to save the running configuration to the startup-config file.

3. Access the configuration level of the CLI by entering the following command.

```
PowerConnect# configure terminal Privileged EXEC Level  
PowerConnect(config)# Global CONFIG Level
```

4. Configure the IP address and mask for the switch.

```
PowerConnect(config)# ip address 192.22.3.44 255.255.255.0
```

5. Set a default gateway address for the switch.

```
PowerConnect(config)# ip default-gateway 192.22.3.1
```

NOTE

You do not need to assign a default gateway address for single subnet networks.

Syntax: enable [<password>]

3 Connecting network devices

Syntax: configure terminal

Syntax: [no] ip address <ip-addr> <ip-mask>

or

Syntax: [no] ip address <ip-addr>/<mask-bits>

Syntax: ip default-gateway <ip-addr>

Connecting network devices

Dell PowerConnect devices support connections to routers, switches, and hubs from other vendors, as well as other Dell PowerConnect devices.

Connectors and cable specifications

Refer to [“Cable specifications”](#) on page 53 for cable lengths and types supported on the PowerConnect B-Series TI24X devices. For port pinouts, refer to [“10/100/1000 Gigabit port pinouts”](#) on page 53.

Connecting to Ethernet or fast Ethernet hubs

For copper connections to Ethernet hubs, a 10/100Base-TX or 1000Base-T switch, or another Dell PowerConnect device, a crossover cable is required ([Figure 10](#) and [Figure 11](#)). If the hub is equipped with an uplink port, it will require a straight-through cable instead of a crossover cable.

NOTE

The 802.3ab standard (automatic MDI or MDIX detection) calls for automatic negotiation of the connection between two 1000Base-T ports. Therefore, a crossover cable may not be required; a straight-through cable may work as well. For more information about this feature, refer to the *PowerConnect B-Series TI24X Configuration Guide*.

FIGURE 10 UTP crossover cable

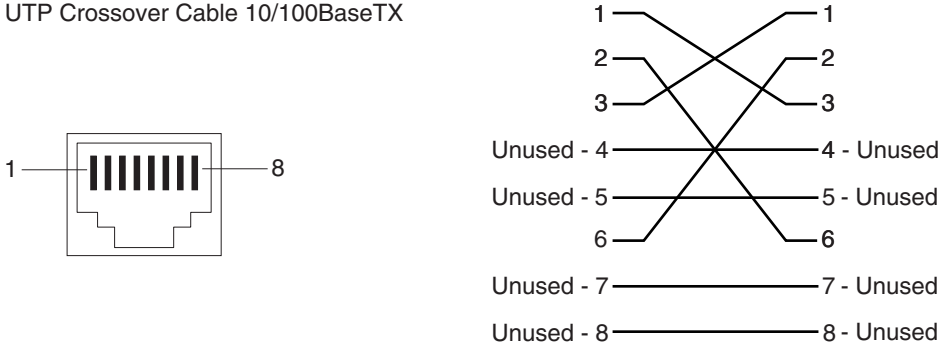
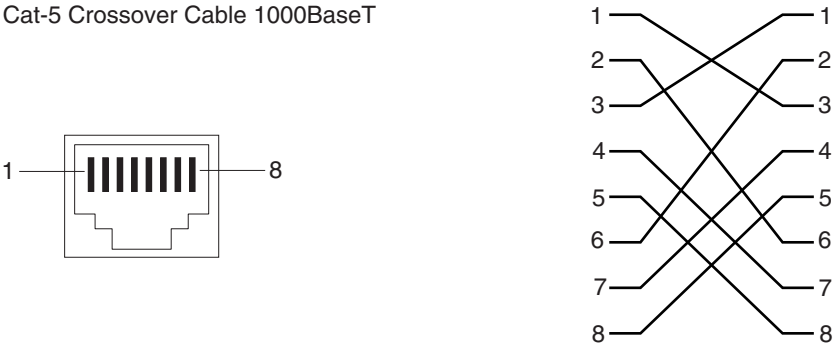

FIGURE 11 Cat-5 crossover cable for 1000Base-T



NOTE
 The 802.3ab standard calls for automatic negotiation of the connection between two 1000Base-T ports. Consequently, a crossover cable may not be required; a straight-through cable may work as well.

Connecting to workstations, servers, or routers

Straight-through UTP cabling is required for direct UTP attachment to workstations, servers, or routers using network interface cards (NICs).

Fiber cabling is required for direct attachment to Gigabit NICs or switches and routers through fiber ports. Refer to [“Connecting a network device to a fiber port”](#).

Automatic MDI or MDIX detection

All 10/100/1000 Copper ports on the Dell PowerConnect B-Series TI24X devices support automatic Media Dependent Interface (MDI) and Media Dependent Interface Crossover (MDIX) detection. This feature is enabled on all Gigabit copper ports by default. For each port, you can disable auto MDI or MDIX, designate the port as an MDI port, or designate the port as an MDIX port.

For more information about this feature and how to configure it, refer to the *PowerConnect B-Series T124X Configuration Guide*.

Connecting a network device to a fiber port

For direct attachment from the Dell PowerConnect device to a Gigabit NIC, switch, or router, fiber cabling with an LC connector is required.

To connect the Dell PowerConnect device to another network device using a fiber port, you must do the following:

- Install a fiber optic module (SFP transceiver or mini-GBIC for Gigabit Ethernet ports, or SFP+ transceiver for 10-Gigabit Ethernet ports)
- Cable the fiber optic module

The following sections provide information about performing these tasks.

Installing a fiber optic module

You must install a fiber optic module (SFP or SFP+ transceiver) in each Gigabit Ethernet and 10-Gigabit Ethernet fiber port you want to use.

You can install a new fiber optic module in a port while the Dell PowerConnect device is powered on and running.

To install a fiber optic module, you will need an ESD wrist strap.



DANGER

For safety reasons, the ESD wrist strap should contain a series 1 meg ohm resistor.

Follow the steps to install a fiber optic module.

1. Put on the ESD wrist strap and ground yourself by attaching the clip end to a metal surface (such as an equipment rack) to act as ground.
2. Remove the new module from its protective packaging.
3. Gently insert the fiber optic module into the port until the module clicks into place. The module is keyed to prevent incorrect insertion.

Cabling a fiber optic module

Follow the steps to cable a fiber optic module.

1. Remove the protective covering from the fiber-optic port connectors and store the covering for future use.
2. Before cabling a fiber optic module, *Dell* strongly recommends that the cable connectors and the port connectors are cleaned thoroughly.
3. Gently insert the cable connector or connectors (a tab on each connector should face upward) into the port connector or connectors until the tabs lock into place.
4. Observe the link and active LEDs to determine if the network connections are functioning properly. Refer to [Table 5](#).

Fiber-optic connectors

To avoid problems with the connection between the fiber optic module (SFP (mini-GBIC) or SFP+) and the fiber cable connectors.

When not using an SFP or SFP+ connector, use the protective covering from the fiber-optic port connectors.

Testing connectivity

After you install the network cables, you can test network connectivity to other devices by pinging those devices. You also can observe the LEDs related to network connection and perform trace routes.

Pinging an IP address

To verify that a PowerConnect B-Series TI24X device can reach another device through the network, enter a command such as the following at any level of the CLI on the PowerConnect device.

```
PowerConnect> ping 192.33.4.7
```

Syntax: ping <ip addr> | <hostname> [source <ip addr>] [count <num>] [timeout <msec>] [ttl <num>] [size <byte>] [quiet] [numeric] [no-fragment] [verify] [data <1-to-4 byte hex>] [brief]

NOTE

If you address the ping to the IP broadcast address, the device lists the first four responses to the ping.

Observing LEDs

After you install the network cables, you can observe certain LEDs to determine if the network connections are functioning properly. [Table 5](#) describes the LEDs related to network connections, the desired state of each LED, possible abnormal states of each LED, and what to do if an LED indicates an abnormal state.

TABLE 5 Network connection-related LED states

LED	Desired State	Meaning	Abnormal State	Meaning or Action
Link (Lnk)	On (Green)	A link is established with the remote port.	Off	<p>A link is not established with the remote port. You can do the following:</p> <ul style="list-style-type: none"> • Verify that the connection to the other network device has been properly made. Also, make certain that the other network device is powered on and operating correctly. • Verify that the transmit port on the Dell PowerConnect device is connected to the receive port on the other network device, and that the receive port on the Dell PowerConnect device is connected to the transmit port on the other network device. If you are uncertain, remove the two cable connectors from the port connector and reinsert them in the port connector, reversing their order. • Dust may have accumulated in the cable connector or port connector. For information about cleaning the connectors, refer to “Fiber-optic connectors”. • If the other actions don't resolve the problem, try using a different port or a different cable.
Active (Act)	On or blinking (Yellow)	The port is transmitting and receiving user packets.	Off for an extended period.	<p>The port is not transmitting or receiving user packets. You can do the following:</p> <ul style="list-style-type: none"> • Check the Link LED to make sure the link is still established with the remote port. If not, take the actions described in the Meaning or Action column for the Link LED. • Verify that the port has not been disabled through a configuration change. You can use the CLI. If you have configured an IP address on the device, you also can use <i>Brocade Network Advisor</i>.

If a problem persists after taking these actions, contact *Dell* technical support.

Tracing a route

To determine the path through which a Dell PowerConnect device can reach another device, enter a command such as the following at any level of the CLI on the PowerConnect device.

```
PowerConnect> traceroute 192.33.4.7
```

Syntax: traceroute <host-ip-addr> [maxttl <value>] [minttl <value>] [numeric] [timeout <value>] [source-ip <ip addr>]

The CLI displays trace route information for each hop as soon as the information is received. Traceroute requests display all responses to a given Time-To-Live (TTL). In addition, if there are multiple equal-cost routes to the destination, the Dell PowerConnect device displays up to three responses by default.

Troubleshooting network connections

- For the indicated port, verify that both ends of the cabling (at the PowerConnect device and the connected device) are snug.
- Verify that the PowerConnect device and the connected device are both powered on and operating correctly.
- Verify that you have used the correct cable type for the connection:
 - For twisted-pair connections to an end node, use straight-through cabling.
 - For fiber-optic connections, verify that the transmit port on the device is connected to the receive port on the connected device, and that the receive port on the device is connected to the transmit port on the connected device.
- Verify that the port has not been disabled through a configuration change. You can use the CLI. If you have configured an IP address on the device, you also can use *IronView Network Manager*.
- For copper ports, you can test the cable using Virtual Cable Testing (VCT). Refer to "Monitoring Hardware Components" in the *PowerConnect B-Series TI24X Configuration Guide*.
- If the other procedures don't resolve the problem, try using a different port or a different cable.

Support for digital optical monitoring

You can configure your PowerConnect device to monitor optical transceivers in the system, either globally or by specified port. When this feature is enabled, the system monitors the temperature and signal power levels for the optical transceivers in the specified ports. Console messages and syslog messages are sent when optical operating conditions fall below or rise above the SFP+ or SFP manufacturer recommended thresholds. For more information about digital optical monitoring, refer to the *PowerConnect B-Series TI24X Configuration Guide*.

3 Troubleshooting network connections

Managing the PowerConnect B-Series T124X

In this chapter

- [Managing temperature settings](#) 33
- [Removing MAC address entries](#) 35

Managing temperature settings

This section describes how to display temperature settings on the PowerConnect B-Series T124X and how to change the temperature warning levels.

Using the temperature sensor

The PowerConnect B-Series T124X comes with two built-in temperature sensors; one at the air intake, and the other at the exhaust (refer to [Figure 25](#) on page 51). The temperature sensor at the air intake monitors the incoming air temperature. The temperature sensor at the air exhaust monitors the air temperature as it exits the device. The temperature sensors cause the device to generate a Syslog message and SNMP trap if the temperature exceeds a specified warning level. The software reads the temperature sensors according to the device poll time, which is 60 seconds by default. If the temperature equals or exceeds the warning temperature the software generates a Syslog message and SNMP trap.

You can use the CLI to perform the following:

- [“Displaying the temperature”](#)
- [“Changing the temperature warning level”](#)
- [“Changing the device temperature polling interval”](#)

Displaying the temperature

By default, the software polls the temperature sensor every 60 seconds to get the current temperature. This poll rate is controlled by the device poll time, which also controls how often the software polls other system components.

To display the temperature of a device, enter the **show chassis** command at any level of the CLI. The following shows an example output.

```
PowerConnect#show chassis
Power supply 1 (NA - NA - Regular) present, status ok
Power supply 2 not present

Fan 1 ok, speed (auto): [[1]]<->2<->3
Fan 2 ok, speed (auto): [[1]]<->2<->3
Fan 3 ok, speed (auto): [[1]]<->2<->3
```

4 Managing temperature settings

```
Fan controlled temperature: 0.0 deg-C

Fan speed switching temperature thresholds:
  Speed 1: NM<----->30                deg-C
  Speed 2:  25<----->40                deg-C
  Speed 3:   35<----->90                deg-C (shutdown)

Boot Prom MAC: 0011.1122.2233
```

Displaying temperature messages

The software sends a Syslog message and an SNMP trap if the temperature crosses the warning threshold. The following methods describe how to view the system log on the device. If you have configured the device to use a Syslog server or SNMP trap receiver, refer to the documentation for the server or receiver.

To display the system log, enter the following command at any CLI level.

```
PowerConnect# show log
Syslog logging: enabled (0 messages dropped, 0 flushes, 0 overruns)
Buffer logging: level ACDMEINW, 8 messages logged
level code: A=alert C=critical D=debugging M=emergency E=error
I=informational N=notification W=warning
Static Log Buffer:
Dynamic Log Buffer (50 entries):
at 0 days 0 hours 2 minutes 0 seconds, level alert
Temperature 48.0 C degrees, warning level 45.0 C degrees
at 0 days 0 hours 1 minutes 0 seconds, level alert
Temperature 50.0 C degrees, warning level 45.0 C degrees
```

Changing the temperature warning level

The default warning temperature is 45.0 C degrees. You can change the warning temperature using the **temperature warning** command. The valid range is 0 - 125 C degrees.

PowerConnect B-Series TI24X devices automatically reset and reload the software when the internal temperature reaches or exceeds the configured shutdown level for five minutes. The PowerConnect B-Series TI24X has the capability to register negative temperature settings.

To change the temperature at which the device sends a warning, enter a command such as the following at the Privileged EXEC level of the CLI.

```
PowerConnect# temperature warning 47
```

Syntax: temperature warning <value>

NOTE

The <value> can be 0 - 125.

Changing the device temperature polling interval

The software reads the temperature sensor and polls other hardware sensors according to the value set for the device poll time, which is 60 seconds by default. You can change the device poll time using the CLI.

To change the device poll time, enter a command such as the following at the global CONFIG level of the CLI.

```
PowerConnect(config)# chassis poll-time 200
```

Syntax: chassis poll-time <value>

NOTE

The <value> can be 0 - 65535 seconds.

Removing MAC address entries

You can remove learned MAC address entries from the *Dell* system MAC address table. You can remove the following entries:

- All MAC address entries
- All MAC address entries for a specified Ethernet port
- All MAC address entries for a specified VLAN
- A specified MAC address entry in all VLANs

For example, to remove entries for the MAC address 000d.cb80.00d in all VLANs, enter the following command at the Privileged EXEC level of the CLI.

```
PowerConnect# clear mac-address 000d.cb80.00d0
```

Syntax: clear mac-address <mac-address> | ethernet <port-num> | vlan <number>

If you enter the **clear mac-address** command without any parameters, the software removes all MAC entries.

Use the <mac-address> parameter to remove a specified MAC address from all VLANs. Specify the MAC address in the following format: HHHH.HHHH.HHHH.

Use the **ethernet** <port-num> parameter to remove all MAC addresses for a specified Ethernet port.

Use the **vlan** <number> parameter to remove all MAC addresses for a specified VLAN.

4 Removing MAC address entries

Maintaining the PowerConnect B-Series TI24X Hardware

In this chapter

- [Hardware maintenance schedule](#) 37
- [Replacing a fiber optic module](#)..... 37
- [Replacing a power supply](#) 39
- [Replacing the fan tray](#) 45

Hardware maintenance schedule

This chapter provides instructions for maintaining the PowerConnect B-Series TI24X hardware.



DANGER

The procedures in this manual are for qualified service personnel.

The PowerConnect B-Series TI24X switch hardware components require minimal maintenance. Dell recommends that you clean the fiber-optic connectors on fiber-optic ports and the connected fiber cable each time you disconnect the cable.

You can replace the following hardware components as needed:

- Fiber optic modules (SFP+ transceivers)
- Power supplies
- Fan tray

Replacing a fiber optic module

You can remove an SFP or SFP+ from a port and replace it with a new one while the PowerConnect B-Series TI24X is powered on and running.

This section provides information about the following tasks:

- [“Removing a fiber optic module”](#)
- [“Installing a new fiber optic module”](#)
- [“Cabling a fiber optic module”](#)

Removing a fiber optic module

You can remove a fiber SFP+ (also called a Small Form-factor Pluggable Plus) or an SFP from a port while the PowerConnect B-Series TI24X is powered on and running.

Before removing a fiber optic module, you will need an ESD wrist strip.



DANGER

For safety reasons, the ESD wrist strap should contain a series 1 meg ohm resistor.

- The protective covering that you removed from the fiber optic module when you initially installed the module.

Follow the steps to remove a fiber optic module from a Gigabit Ethernet or 10-Gigabit Ethernet port.

1. Put on the ESD wrist strap and ground yourself by attaching the clip end to a metal surface (such as an equipment rack).
2. Disconnect the fiber cable connector from the port connector.
3. Insert the protective covering into the port connector or connectors.
4. Pull the fiber optic module out of the port by pulling the latch forward, away from the front panel of the module as shown in [Figure 12](#). This unlocks the module from the front panel. On 1000BaseSX ports, the latch is enclosed in a black sleeve, and on 1000BaseLX ports, the bail latch is enclosed in a blue sleeve.

FIGURE 12 Disconnecting a fiber optic module latch

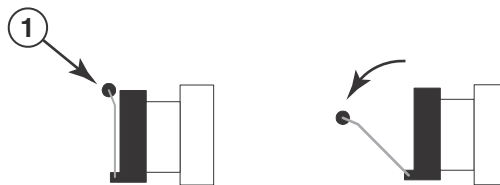

1 Bail Latch

NOTE

The latch may be attached to either the top or the bottom of the optical module.

5. Grasp the latch and pull the fiber optic module out of the port.

FIGURE 13 Removing a fiber optic module

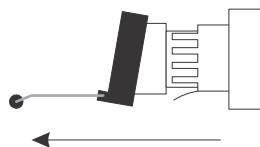

6. Store the fiber optic module in a safe, static-free place or in an anti-static bag.

7. Install a new fiber optic module in the port. For information about performing this task, refer to [“Installing a new fiber optic module”](#).

Installing a new fiber optic module

You must install a fiber optic module (SFP+ or SFP transceiver) in each 10-Gigabit Ethernet fiber port you want to use. You can install a new fiber optic module in a port while the PowerConnect B-Series TI24X device is powered on and running.

To install a fiber optic module, you will need an ESD wrist strap.



DANGER

For safety reasons, the ESD wrist strap should contain a series 1 meg ohm resistor.

Follow the steps to install a fiber optic module.

1. Put on the ESD wrist strap and ground yourself by attaching the clip end to a metal surface (such as an equipment rack) to act as ground.
2. Remove the new module from its protective packaging.
3. Gently insert the fiber optic module into the port until the module clicks into place. The module is keyed to prevent incorrect insertion.

Cabling a fiber optic module

Follow the steps to cable a fiber optic module.

1. Remove the protective covering from the fiber-optic port connectors and store the covering for future use.
2. Before cabling a fiber optic module, Dell strongly recommends that the cable connectors and the port connectors are cleaned thoroughly.
3. Gently insert the cable connector or connectors (a tab on each connector should face upward) into the port connector or connectors until the tabs lock into place.
4. Observe the link and active LEDs to determine if the network connections are functioning properly. For more information about the LED indicators, refer to [Table 5](#) on page 30.

Fiber-optic connectors

To avoid problems with the connection between the fiber optic module (SFP+ or SFP) and the fiber cable connectors. When not using an SFP+ or SFP connector, make sure to keep the protective covering on.

Replacing a power supply

You can replace a power supply while the PowerConnect B-Series TI24X is powered on and running (if two power supplies are installed). The power supplies are located in slots at the rear of the PowerConnect B-Series TI24X .

5 Replacing a power supply

This section provides information about the following topics:

- Installation precautions and warnings
- Determining which power supply failed
- Replacing a power supply



DANGER

Power supplies are hot swappable. However, Dell recommends that you disconnect the power supply from AC power before installing or removing the supply. The device can be running while a power supply is being installed or removed, but the power supply itself should not be connected to a power source. Otherwise, you could be injured or the power supply or other parts of the device could be damaged.

Installation precautions and warnings

Follow these precautions when installing a power supply in the PowerConnect B-Series TI24X .



DANGER

Before beginning the installation, refer to the precautions in [“Power precautions”](#) on page 12.



CAUTION

Do not install the device in an environment where the operating ambient temperature might exceed 40°C (104°F).



CAUTION

Never leave tools inside the device.

Determining which power supply failed

The **Show Chassis** command displays status information for the power supplies and the fans. If you are not sure which Power supply has failed or you not applid AC Voltage, enter the following command at any CLI command prompt:

```
PowerConnect# show chassis
Power supply 1 (NA - NA - Regular) present, status ok
Power supply 2 not present
Fan 1 ok, speed (auto): [[1]]<->2<->3
Fan 2 ok, speed (auto): [[1]]<->2<->3
Fan 3 ok, speed (auto): [[1]]<->2<->3
Fan controlled temperature: 0.0 deg-C
Fan speed switching temperature thresholds:
    Speed 1: NM<----->30                deg-C
    Speed 2:  25<----->40                deg-C
    Speed 3:   35<----->90                deg-C (shutdown)
```

Boot Prom MAC: 0011.1122.2233

The power supplies are numbered from left to right. These numbers assume you are facing the front of the device, not the rear.

If the display indicates "Installed (Failed)" for any of the slots, the power supply installed in that particular slot has failed.

AC power supplies

Use the following procedures for AC power supplies in PowerConnect B-Series TI24X devices.



DANGER

Before beginning the installation, refer to the precautions in ["Power precautions"](#) on page 12.

You will need a #2 Phillips-head screwdriver to perform these procedures.

[Figure 14](#) shows a front view of the AC power supply.

FIGURE 14 AC power supply

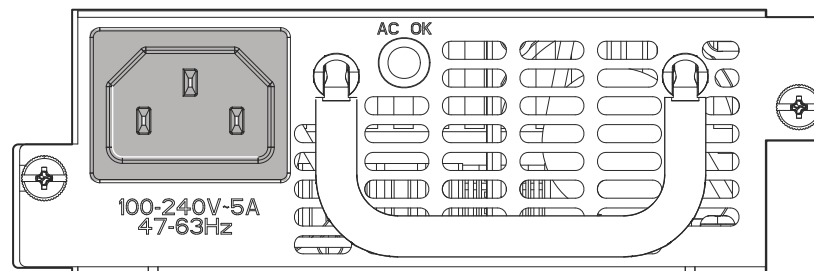

Removing an AC power supply

Follow the steps to remove an AC power supply.

1. Unplug the PDU power cords (C13-C14) from the power source.
2. Disconnect the PDU power cords (C13-C14) from the power supply.

5 Replacing a power supply

3. Loosen the two captive power supply locking screws located on the sides of the power supply.

FIGURE 15 Releasing the power supply

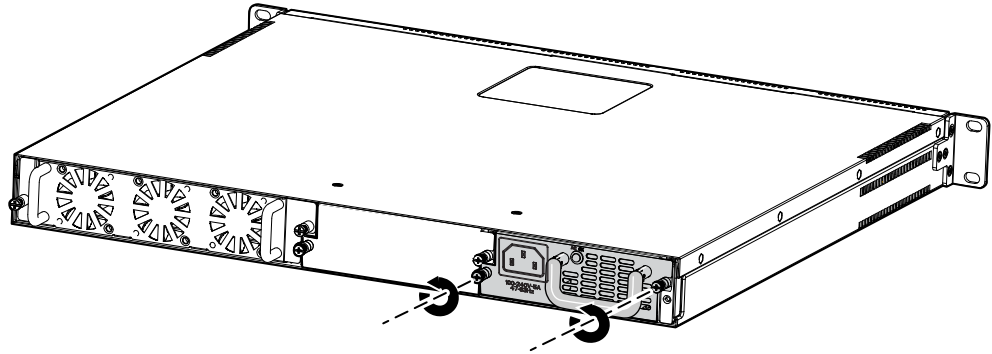

4. Hold the handle on the front panel of the power supply and pull outward. This will disconnect the power supply from the backplane.
5. Continue to pull the power supply until it is removed from the device.

FIGURE 16 Removing the power supply

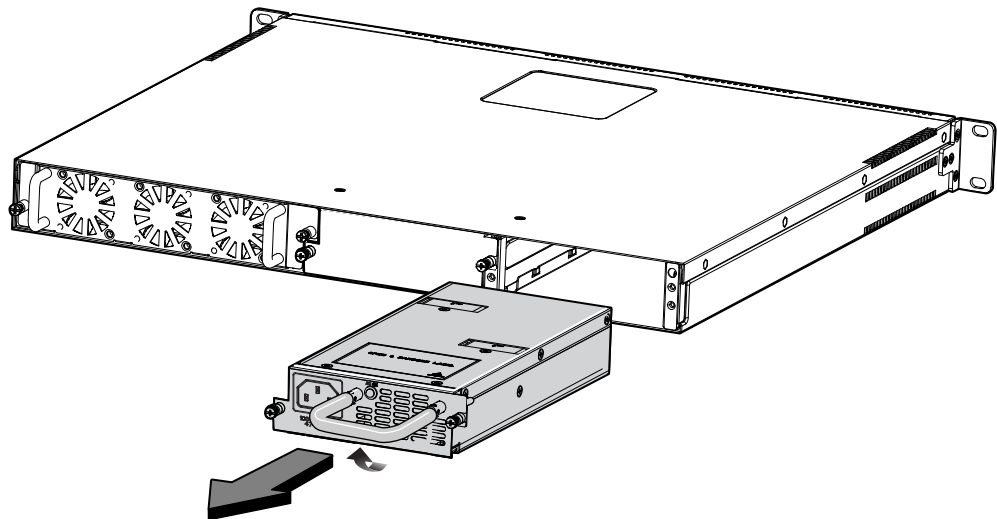

6. Place the power supply in an anti-static bag for storage.

Installing an AC power supply

NOTE

If the empty power supply bay has a cover plate, remove it as shown below before continuing.

FIGURE 17 Releasing the cover plate

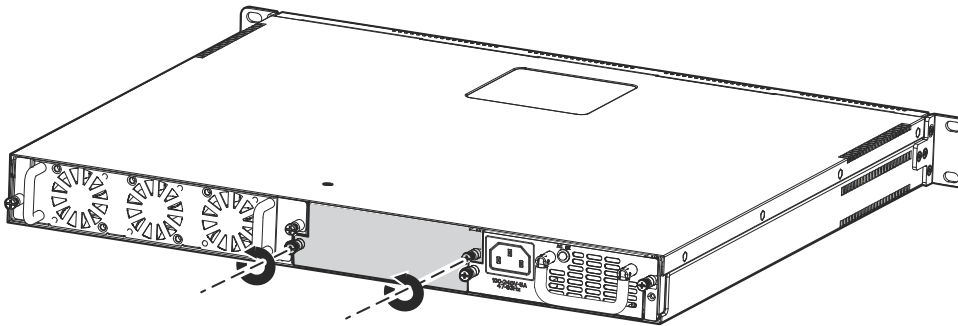
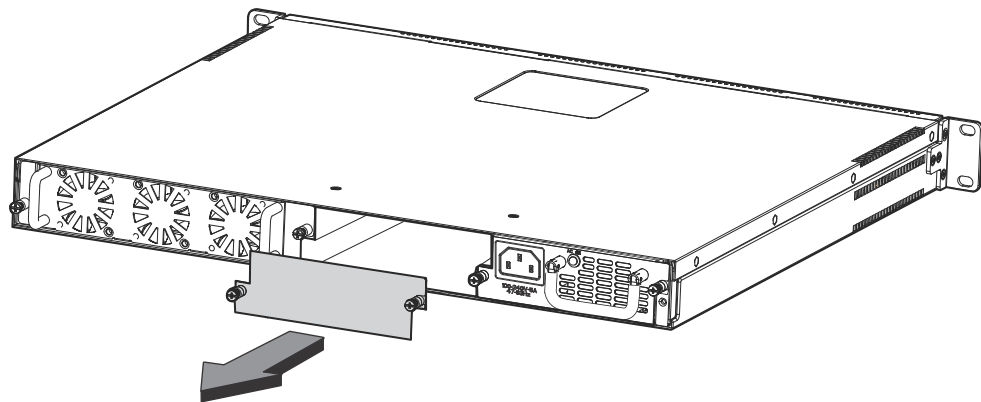

FIGURE 18 Removing the cover plate



1. Remove the new power supply from its packaging.
2. Hold the handle on the front panel of the power supply with one hand and ensure that the alignment pin on the right side of the power supply is correctly aligned. With the other hand, support the underside of the power supply, and insert the power supply into the empty power supply slot.

5 Replacing a power supply

3. Push inward until the supply is completely in the slot, so that the connectors on the back of the supply fully engage with the pins on the power backplane.



DANGER

Make sure you insert the power supply right-side up. It is possible to insert the supply upside down, although the supply will not engage with the power backplane when upside down. The power supply is right-side up when the power connector is on the left and the fan vent is on the right.

FIGURE 19 Installing the power supply

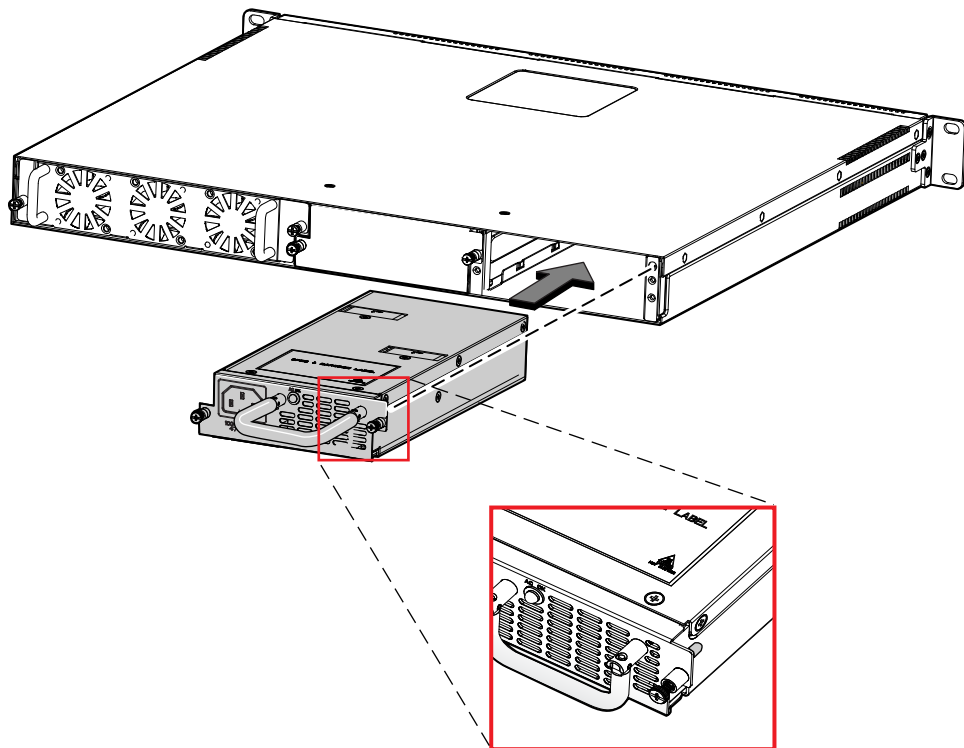

4. Lock the power supply in place by securing the two captive screws as shown in [Figure 20](#).

FIGURE 20 Securing the power supply in the device

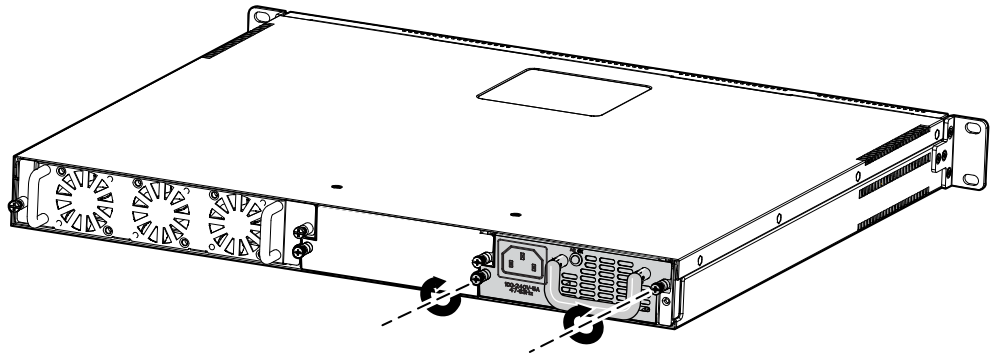

5. Connect the PDU power cords (C13-C14) to the power supply.

FIGURE 21 Connecting the PDU power cords (C13-C14)

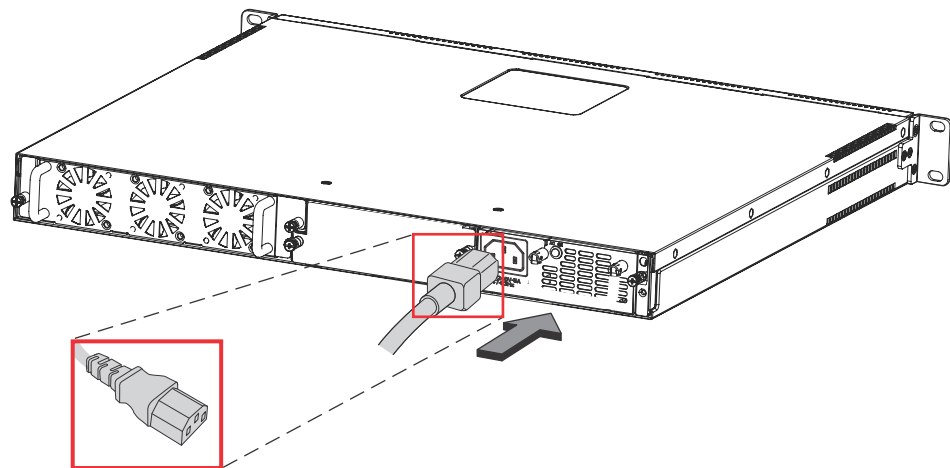

6. Power on the supply and verify that it is working properly as instructed in [“Powering on the system”](#) on page 18 and [“Verifying proper operation”](#) on page 19.

Replacing the fan tray

NOTE

You can replace the fan tray while the PowerConnect B-Series TI24X device is powered on and running. But, you need to replace the fan tray quickly after removing it from the device, otherwise the device will overheat.

The fan tray is located in a slot at the rear of the PowerConnect B-Series TI24X .

This section provides information about the following topics:

5 Replacing the fan tray

- Installation precautions and warnings
- Replacing the fan tray

Installation precautions and warnings

Follow these precautions when removing and installing a fan tray in the PowerConnect B-Series TI24X .



CAUTION

Be careful not to accidentally insert your fingers into the fan tray while removing it from the chassis. The fan may still be spinning at a high speed.



CAUTION

Do not install the device in an environment where the operating ambient temperature might exceed 40°C (104°F).



CAUTION

Never leave tools inside the device.

Removing the fan tray

Use the following procedures to remove the fan tray from PowerConnect B-Series TI24X devices.

Figure 22 shows the location of the fan tray.

FIGURE 22 PowerConnect B-Series TI24X fan tray location

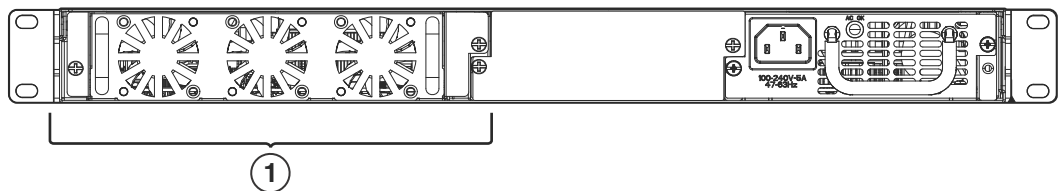

1 Fan Tray

1. Disconnect the PDU power cords (C13-C14) from the power supply.

NOTE

If the device is connected with two Power supplies, you need to disconnect both the PDU power cords (C13-C14) from the device.

- Loosen the two captive screws on the front plate of the fan tray and slide the tray out of the device as shown in [Figure 23](#).

FIGURE 23 Removing the fan tray

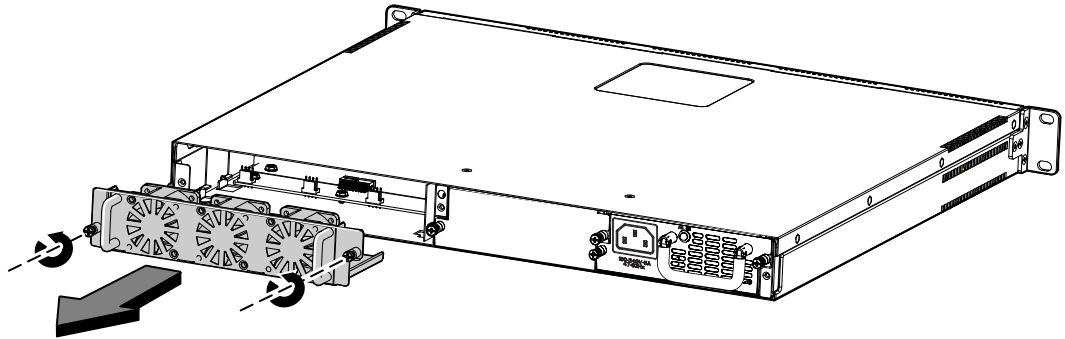

- Insert the replacement fan tray, as shown in [Figure 24](#), and push it all the way into the slot to connect the interface.

NOTE

Ensure that the fan tray fits between the locating slides in the device.

- Tighten the two captive screws to secure the tray in place.

FIGURE 24 Inserting a replacement fan tray

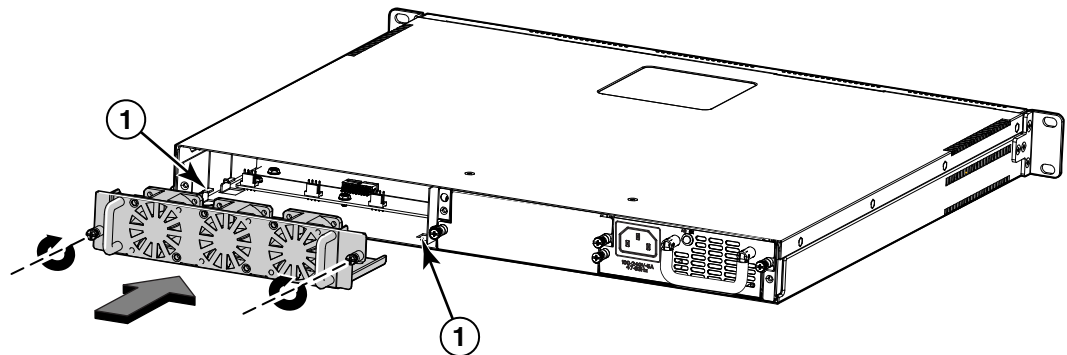

- Locating Slide

- Connect the PDU power cords (C13-C14) to the power supply (refer to [“Powering on the system”](#) on page 18).
- Verify that the system is working properly as instructed in [“Verifying proper operation”](#) on page 19.

5 Replacing the fan tray

Hardware Specifications

This chapter contains the following hardware specifications for PowerConnect B-Series T124X devices.

Device specifications

- “Physical dimensions and weight”
- “Environmental considerations”
- “Cooling”
- “Regulatory compliance”
- “Power source interruptions”
- “Mean Time between Failure”
- “Pinouts and signalling”
- “Cable specifications”
- “PDU power cords(C13-C14)”

Power supply specifications

- “Overview”
- “Key features”
- “Physical dimensions and weight”
- “Environmental considerations”
- “Power supply consumption”
- “Input connector and plug”
- “Regulatory compliance”
- “Safety warnings”
- “Electrical specifications”

Device specifications

The following sections provide hardware specifications for the PowerConnect B-Series T124X.

Physical dimensions and weight

Table 6 lists the physical dimensions and weight of PowerConnect B-Series T124X and modules.

TABLE 6 Physical dimensions and weight of the PowerConnect B-Series T124X and modules

Platform	Height	Width	Depth	Weight
PowerConnect B-Series T124X	(4.28 cm) 1.68 in.	(43.5 cm) 17.12 in.	(39.37 cm) 15.5 in.	<ul style="list-style-type: none"> (7.4 kg) 16.28 lbs including dual power supplies (6.01 kg) 13.22 lbs single power supply

Environmental considerations

For optimal performance, operate or store your *Dell* PowerConnect B-Series T124X device in compliance with the following environmental conditions.

Operating environment

TABLE 7 Operating environmental conditions for the device

Description	Range
Operating temperature	0° - 40°C (32° - 104°F)
Relative humidity	5 to 95%, @ 40°C (104°F), non-condensing
Operating noise	65 dB
Maximum heat dissipation	689 BTU/Hr

Storage environment

TABLE 8 Storage environmental conditions for the device

Description	Range
Storage temperature	-25° to 70°C (-23° to 158°F)
Storage humidity	80% maximum, non-condensing

Cooling

The PowerConnect B-Series T124X has three speed-adjustable fans that operate simultaneously. If one fan fails, it does not affect the operation of the other fans. The cooling fans cool the CPU, main memory, and voltage regulators. The fans use a pull configuration Front to Back (FtB) to intake air from the front left and right sides through the device and then expel it at the rear of the device as shown in [Figure 25](#).

FIGURE 25 Device air flow

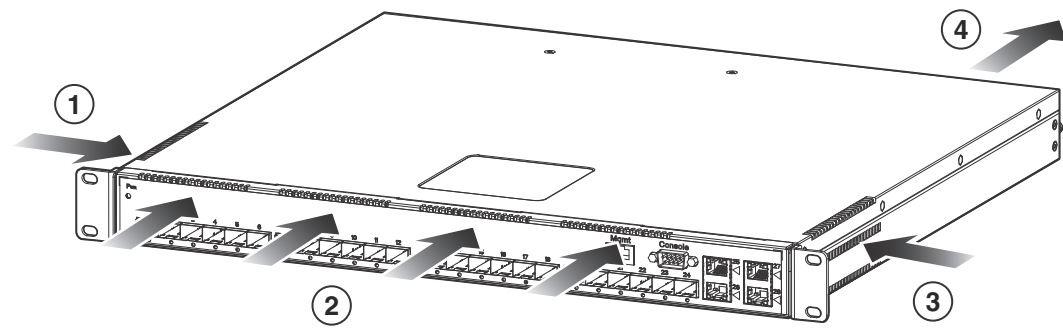

- 1 Left intake
- 2 Front intakes
- 3 Right intake
- 4 Exhaust

- Total cooling capacity: 200 watts
- Total air flow: 150 LFM
- Fan operating noise: < 65 dB-A.

NOTE

Operating noise is based on the ISO 7779 standard.

Regulatory compliance

Table 9 lists the Electromagnetic Compatibility (EMC), Immunity standards, and safety agency approvals for PowerConnect B-Series TI24X switches.

TABLE 9 Device regulatory compliance

Description	Certifications
Electromagnetic Emissions	CISPR-22 Class A
	EN 55022
	FCC Class A (Part 15)
	VCCI Class A
Immunity	EN 50024:1998
Safety	EN 60950-1, 2nd Edition
	CAN/CSA C22.2 No.60590-1-07, 2nd Edition
	EN 60825-1, Safety of Laser Products - Part 1
	EN 60825-2, Safety of Laser Products - Part 2
	IEC 60950-1, 2nd Edition
	UL 60950-1, 2nd Edition

Power source interruptions

Table 10 shows how the PowerConnect B-Series TI24X protects against power surges and power drops.

TABLE 10 Device power surge and drop protection

Property	Protection Mechanism
Power surge	MOV and Spark Gap protection
Power drop	The PSU will shut down after AC loss >20ms
Maximum power draw	300 watts

Mean Time between Failure

Table 11 lists the Mean Time between Failure (MTBF) for the PowerConnect B-Series TI24X. The MTBF is the average estimated time, in hours, before a hardware failure may occur.

TABLE 11 MTBF for the PowerConnect B-Series TI24X

Configuration or Module	Temperature	MTBF (hours)
PowerConnect B-Series TI24X	(40°C) 104°F	114,572

Pinouts and signalling

This section lists the pinouts for the DB-9 connector and RJ-45 port jacks.

Serial (Console) port pinouts

The Console port is a standard male DB-9 connector, as shown in Figure 26.

FIGURE 26 Serial port pin and signalling details

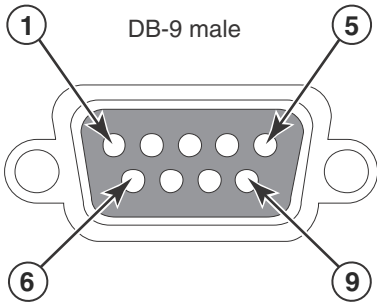
Pin Assignment	Pin Number	Switch Signal
 <p>DB-9 male</p>	1	Reserved
	2	TXD (output)
	3	RXD (input)
	4	Reserved
	5	GND
	6	Reserved
	7	CTS (input)
	8	RTS (output)
	9	Reserved

Most PC serial ports also require a cable with a female DB-9 connector. Terminal connections will vary, requiring either a DB-9 or DB-25 connector, male or female.

Serial cable options between the PowerConnect B-Series TI24X and a PC or terminal are shown in Figure 27.

FIGURE 27 Serial port pin assignments showing cable connection options to a terminal or PC

DB-9 to DB-9 Female Switch			Terminal or PC	DB-9 to DB-25 Female Switch			Terminal or PC
1	Reserved		1	1	Reserved	8	
2		→	2	2		3	
3		←	3	3		2	
4	Reserved		4	4	Reserved	20	
5		→	5	5		7	
6	Reserved		6	6	Reserved	6	
7		←	7	7		4	
8		→	8	8		5	
9	Reserved		9	9	Reserved	22	

As indicated in [Figure 26](#) and [Figure 27](#), some of the wires should not be connected. Connecting the wires that are labeled "Reserved" may generate unexpected results with some terminals.

10/100/1000 Gigabit port pinouts

[Figure 28](#) lists the pin assignment and signalling for 10/100/1000 ports.

FIGURE 28 Pin assignment and signalling for 10/100/1000 ports

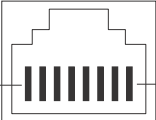
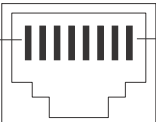
Pin Assignment	10BaseT		100BaseTX and 1000BaseT	
	Pin Number	MDI-X ports	Pin Number	MDI-X ports
	1	RD+	1	RD+
	2	RD-	2	RD-
	3	TD+	3	TD+
	4	Not used	4	CMT
	5	Not used	5	CMT
	6	TD-	6	TD-
	7	Not used	7	CMT
	8	Not used	8	CMT

Cable specifications

[Table 12](#) lists the cable specifications for the cables used with the Gigabit, and 10-Gigabit Ethernet ports.

A Device specifications

NOTE

Cable installation and network configuration will affect overall transmission capability. The numbers provided here represent the accepted recommendations of the various standards. For network-specific recommendations, consult your local PowerConnect B-Series TI24X devices reseller or system engineer.

TABLE 12 Cable length summary

Cable Type		Connector Type	Core Diameter (microns)	Modal Bandwidth (MHz*km) or Wavelength (nm)	Range (meters)
1000Base-BX-D	Single-mode Fiber (SMF)	LC connector for SFP module	9	1490 nm	2 - 10000 (10 km)
1000Base-BX-U	SMF	LC connector for SFP module	9	1310 nm	2 - 10000 (10 km)
1000Base-LHA	SMF	LC connector for SFP module	9	1550 nm	2 - 70000 (70 km)
1000Base-LX	Multi-mode Fiber (MMF)	LC connector for SFP module	62.5	500	2 - 550
	MMF		50	400	2 - 550
	MMF		50	500	2 - 550
	SMF		9	1300 nm	2 - 10000
1000Base-SX	MMF	LC connector for SFP module	62.5/125	200	.5 - 275
	MMF		62.5/125	500	.5 - 550
	MMF		50/125	900	.5 - 595
	MMF		50/125	1500	.5 - 740
	MMF		50/125	2000	.5 - 860
1000Base-T	Copper	RJ-45 jack for standard unshielded twisted pair (UTP/ Category 5)	n/a	n/a	up to 100 meters
10GBase-LR	SMF	LC connector for XFP module	9	1310 nm	2 - 10000 (10 km)
10GBase-SR	MMF	LC connector for XFP module	62.5/125	160	2 - 26
	MMF		62.5/125	200	2 - 33
	MMF		50/125	400	2 - 66
	MMF		50/125	500	2 - 82
	MMF		50/125	2000	2 - 300

NOTE

SMF = Single Mode Fiber, MMF = Multi-Mode Fiber.

PDU power cords(C13-C14)

All PowerConnect devices ship with US-compatible PDU power cords(C13- C14) unless otherwise specified at the time of order. United Kingdom- and European-compatible power cords are also available.

For PDU power cords (C13-C14) specifications, refer to [“Input connector and plug”](#) on page 57.

Power supply specifications

This section contains the following information for the power supplies that ship with PowerConnect B-Series TI24X devices.

- [“Overview”](#)
- [“Key features”](#)
- [“Physical dimensions and weight”](#)
- [“Environmental considerations”](#)
- [“Power supply consumption”](#)
- [“Input connector and plug”](#)
- [“Regulatory compliance”](#)
- [“Safety warnings”](#)
- [“Electrical specifications”](#)

Overview

Each PowerConnect B-Series TI24X switch comes with one alternating-current (AC) power supplies. The following power supplies may be installed in your PowerConnect B-Series TI24X switch:

- RPS-11 (8P26P) (AC power supply)

The power supplies can be swapped in or out of the device while the device is running, without opening the device. You can remove one of the power supplies without interrupting operation. The remaining power supply provides enough power for all the ports.



CAUTION

Remove the PDU power cords (C13-C14) from a power supply before you install it in or remove it from the device. Otherwise, the power supply or the device could be damaged. The device can be running while a power supply is being installed or removed, but the power supply itself should not be connected to a power source.

All power supplies are auto-sensing and auto-switching.

Key features

Refer to [“Power supplies”](#) on page 6 for the key features of the PowerConnect B-Series TI24X power supplies.

Physical dimensions and weight

TABLE 13 Physical dimensions and weight of power supplies

Power Supply	Dimensions	Weight
AC	4.06 cm (1.6 in.) (H) x 10.67 cm (4.2 in.) (W) x 22.86 cm (9 in.) (D)	(2.84 lbs) 1.29 kg

Environmental considerations

For optimal performance, operate or store the power supplies in compliance with the following environmental conditions.

Operating environment

TABLE 14 Operating environmental conditions for power supplies

Description	Range
Operating temperature	0° - 40° C (32° - 104° F)
Fan inlet temperature	0° - 40° C (32° - 104° F)
Fan vent temperature	52° - 53° C (125.6° - 127.4° F)
Relative humidity	20 - 90%, non-condensing
Operating altitude	Up to 3030 meters (10000 feet) above sea level
Operating noise	50 dBA
Cooling	AC: 40 mm, internal fans

Storage environment

TABLE 15 Storage environmental conditions for power supplies

Description	Range
Storage temperature	-40° to 85° C (-40° to 185° F)
Storage humidity	95% maximum, non-condensing
Storage altitude	4545.45 meter (15,000 feet) maximum

Power supply consumption

The maximum power supply consumption for each PowerConnect B-Series TI24X model is 300W.

Input connector and plug

Table 16 lists the input connectors for the power supplies.

TABLE 16 Input connector for power supplies

Power Supply	Input Connector Properties
RPS11	Standard IEC 320 C14 type: UL/cUL 15A/250V, VDE 10A/250V Orientation: Ground pin up.

Figure 29 shows the power plug and connector for AC power supplies.

FIGURE 29 AC PDU power cords (C13-C14) plug and input connector

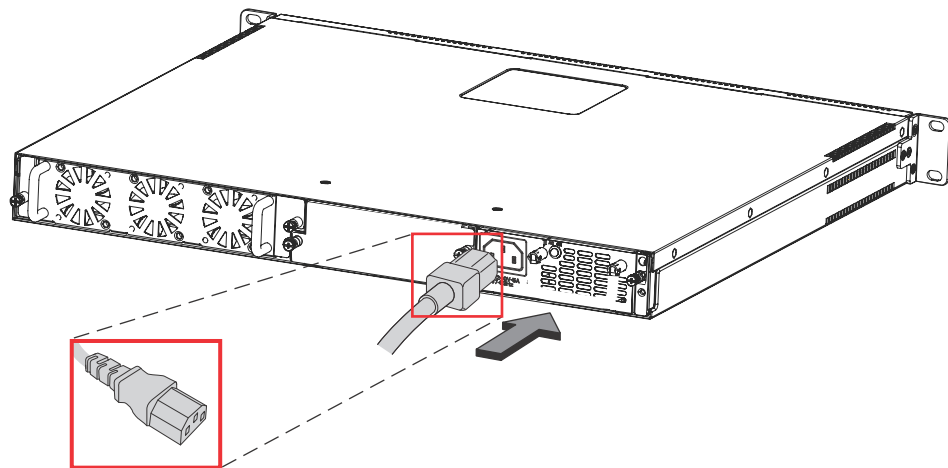

Regulatory compliance

The power supplies comply with the conducted and radiated test, immunity, and safety standards as listed in [Table 17](#).

TABLE 17 Power supply regulatory compliance

Description	Certifications
Electromagnetic Emissions or Immunity EN55024	<ul style="list-style-type: none"> • EN61000-3-2[Harmonics] Class A • EN61000-3-3 [Flicker] • EN61000-4-2 [ESD] Level 3 {4 KV} • EN61000-4-3 [RFI] Level 3 10V/M} • EN61000-4-4 [EFT] Level 3 {2KV} • EN61000-4-5 [Surge] Level 3 {2KV} • EN61000-4-6 [CRFI] Level 3 Performance Criteria A} • EN61000-4-8 [Magnetics] • EN61000-4-11 [Voltage dips & interrupts] • KN 22
Safety	<ul style="list-style-type: none"> • CSA/cUL CAN/CSA C22.2 No. 60950-1-7/ UL 60950-1 2nd Edition • CE "Low Voltage Directive (LVD) (2006/95/EC)" • IEC60950-1:2005 • TUV , EN60950-1:2006

Safety warnings

The power supplies are marked with an electrical hazard label and with the safety warnings shown in [Table 18](#).



CAUTION

No operator serviceable parts inside. Refer servicing to qualified personnel.

TABLE 18 Safety warning labels on power supplies

ATTENZIONE	Non aprire. Rivolgersi a personale qualificado.
CUIDADO	Partes adentro no reparables por el operador. Refiera reparo a personal autorizado.
ATTENTION	Entretien et réparations internes ne sont autorisés qu'au personnel technique qualifié.
GEFAHR	Zugang zur Bedienung nicht erforderlich. Wartung nur durch qualifiziertes Personal.

Electrical specifications

Table 19 lists the electrical specifications for the power supplies.

TABLE 19 Power supply electrical specifications

Description	Ranges
	AC
Input Specifications	
Input voltage range	100 to 240 VAC
Input current	5 Amps
Inrush current	70 amps peak maximum at cold start for a 1/2 cycle at any rated input voltage decaying to the nominal value within 100 milliseconds(240 VAC)
Output Specifications	
Output power	300 watts of total output power



DANGER

The PowerConnect B-Series TI24X power supply is designed exclusively for use with PowerConnect B-Series TI24X devices. Installing the power supply in a device other than the PowerConnect B-Series TI24X will cause extensive damage to your equipment.

A Power supply specifications

Regulatory Approval and Statements

This appendix contains agency approvals and regulatory statements.

Agency approvals

Safety agency approvals

- CAN/CSA C22.2 No. 60950-1-7 / UL60950-1 2nd Edition
- IEC 60950-1: 2005
- EN 60950-1 Safety of information Technology Equipment
- EN 60825-1 Safety of Laser Products—Part1: *Equipment Classification, Requirements and User's Guide*
- EN 60825-2 Safety of Laser Products—Part2: Safety of Optical Fibre Communication Systems

Electromagnetic emission

- ICES-003 Electromagnetic Emission
- FCC Class A
- EN 55022 or CISPR-22 Class A or VCCI ClassA
- AS or ZS 55022
- EN 61000-3-2 Power Line Harmonics
- EN 61000-3-3 Voltage Fluctuation and Flicker
- EN 61000-6-3 Emission Standard (Supersedes: EN 50081-1)

Immunity

- EN 61000-6-1 Generic Immunity and Susceptibility. Supercedes: EN 50082-1
- EN 55024 Immunity Characteristics. Supercedes:
 - EN 61000-4-2 ESD
 - EN 61000-4-3 Radiated, radio frequency, electromagnetic field
 - EN 61000-4-4 Electrical fast transient
 - EN 61000-4-5 Surge
 - EN 61000-4-6 Conducted disturbances induced by radio-frequency fields
 - EN 61000-4-8 Power frequency magnetic field
 - EN 61000-4-11 Voltage dips and sags

Regulatory statements

U.S.A.

This equipment has been tested and found to comply with the limits for a Class A digital device pursuant to Part 15 of the FCC Rules. These limits are designed to provide reasonable protection against harmful interference when the equipment is operated in a commercial environment. This equipment generates, uses, and can radiate radio frequency energy and, if not installed and used in accordance with the instruction manual, may cause harmful interference to radio communications. Operation of this equipment in a residential area is likely to cause harmful interference in which case the user will be required to correct the interference at his own expense.



CAUTION

Changes or modifications made to this device which are not expressly approved by PowerConnect B-Series TI24X devices could void the user's authority to operate the equipment.

Industry Canada statement

Cet appareil numérique de la classe A est conforme à la norme NMB-003 du Canada.

English translation of above statement

This Class A digital apparatus complies with Canadian ICES-003.

Europe and Australia

This is a Class A product. In a domestic environment this product may cause radio interference in which case the user may be required to take adequate measures.

Japan

この装置は、情報処理装置等電波障害自主規制協議会（VCCI）の基準に基づくクラス A 情報技術装置です。この装置を家庭環境で使用すると電波妨害を引き起こすことがあります。この場合には使用者が適切な対策を講ずるよう要求されることがあります。

English translation of above statement

This is Class A product based on the standard of the Voluntary Control Council For Interference by Information Technology Equipment (VCCI). If this equipment is used in a domestic environment, radio disturbance may arise. When such trouble occurs, the user may be required to take corrective actions.

Japan power cords



注意 - 添付の電源コードを他の装置や用途に使用しない

添付の電源コードは本装置に接続し、使用することを目的として設計され、その安全性が確認されているものです。決して他の装置や用途に使用しないでください。火災や感電の原因となる恐れがあります。

English translation of above statement

ATTENTION: Never use the power cords packed with your equipment for other products.

Korea

Class A statement

A 급 기기 (업무용 방송통신기기): 이 기기는 업무용 (A 급) 으로 전자파적합등록을 한 기기이오니 판매자 또는 사용자는 이 점을 주의하시기 바라며, 가정외의 지역에서 사용하는 것을 목적으로 합니다.

English Translation of Above Statement

Class A device (Broadcasting Communication Device for Office Use): This device obtained EMC registration for office use (Class A), and may be used in places other than home. Sellers and/or users need to take note of this.

China RoHS

Restriction on the use of certain hazardous substances in electrical and electronic equipment.

零部件名称	有毒有害物质或元素 Hazardous Substances or Elements					
	铅 (Pb)	汞 (Hg)	镉 (Cd)	六价铬 (Cr6+)	多溴联苯 (PBBs)	多溴二苯醚 (PBDEs)
电源供应器 Power supply	x	o	o	o	o	o
钮扣电池 Button cell	o	o	o	o	o	o
集成电路 Integrated circuit	x	o	o	o	o	o
随机存储设备 Storage devices	x	o	o	o	o	o
电路板组件 Circuit board components	x	o	o	o	o	o
接口适配器 Interface Adapter	o	o	o	o	o	o
信号、电源线 Signal, power cord	o	o	o	o	o	o
风扇 Fan	x	o	o	o	o	o
金属机构件 (包括散热模块、 螺丝紧固件) Metal parts	o	o	o	o	o	o
非金属机构件 Non-metallic parts	o	o	o	o	o	o
<p>x : 电路板组件包括印刷电路板及其构成的零部件 , 如电阻、电容、集成电路、连接器等。 Circuit Assembly including printed circuit boards and component parts, such as resistors, capacitors, integrated circuits, connectors, etc.</p>						
<p>o : 表示该有害物质在该部件所有均质材料中的含量均在《电子信息产品中有毒有害物质的限量要求标准》规定的限量要求以下。 Indicates that this toxic or hazardous substance contained in all of the homogeneous materials for this part is below the limit requirement in SJ/T11363-2006.</p>						

Caution and Danger Notices

Cautions

A caution calls your attention to a possible hazard that can damage equipment.

“Vorsicht” weist auf die Gefahr einer möglichen Beschädigung des Gerätes in.

Une mise en garde attire votre attention sur un risque possible d'endommagement de l'équipement. Ci-dessous, vous trouverez les mises en garde utilisées dans ce manuel.

Un mensaje de precaución le advierte sobre un posible peligro que pueda dañar el equipo. Las siguientes son precauciones utilizadas en este manual.

CAUTION	Do not install the device in an environment where the operating ambient temperature might exceed 40° C (104° F).
VORSICHT	Das Gerät darf nicht in einer Umgebung mit einer Umgebungsbetriebstemperatur von über 40° C (104° F) installiert werden.
MISE EN GARDE	N'installez pas le dispositif dans un environnement où la température d'exploitation ambiante risque de dépasser 40° C (104° F).
PRECAUCIÓN	No instale el instrumento en un entorno en el que la temperatura ambiente de operación pueda exceder los 40° C (104° F).

CAUTION	Remove the PDU power cords (C13-C14) from a power supply before you install it in or remove it from the device. Otherwise, the power supply or the device could be damaged as a result. (The device can be running while a power supply is being installed or removed, but the power supply itself should not be connected to a power source.)
VORSICHT	Nehmen Sie vor dem Anschließen oder Abtrennen des Geräts das Stromkabel vom Netzteil ab. Ansonsten könnten das Netzteil oder das Gerät beschädigt werden. (Das Gerät kann während des Anschließens oder Annehmens des Netzteils laufen. Nur das Netzteil sollte nicht an eine Stromquelle angeschlossen sein.)
MISE EN GARDE	Enlevez le cordon d'alimentation d'un bloc d'alimentation avant de l'installer ou de l'enlever du dispositif. Sinon, le bloc d'alimentation ou le dispositif risque d'être endommagé. (Le dispositif peut être en train de fonctionner lorsque vous installez ou enlevez un bloc d'alimentation, mais le bloc d'alimentation lui-même ne doit pas être connecté à une source d'alimentation.)
PRECAUCIÓN	Retire el cordón de corriente del suministro de corriente antes de instalarlo o retirarlo del instrumento. De no hacerse así, el suministro de corriente o el instrumento podrían resultar dañados. (El instrumento puede estar encendido mientras se instala o retira un suministro de corriente, pero el suministro de corriente en sí no deberá conectado a la corriente).

C Cautions

CAUTION	Make sure the air flow around the front, sides, and back of the device is not restricted.
VORSICHT	Stellen Sie sicher, dass an der Vorderseite, den Seiten und an der Rückseite der Luftstrom nicht behindert wird.
MISE EN GARDE	Vérifiez que rien ne restreint la circulation d'air devant, derrière et sur les côtés du dispositif et qu'elle peut se faire librement.
PRECAUCIÓN	Asegúrese de que el flujo de aire en las inmediaciones de las partes anterior, laterales y posterior del instrumento no esté restringido.

CAUTION	Use a separate branch circuit for each AC PDU power cords (C13-C14), which provides redundancy in case one of the circuits fails.
VORSICHT	Es empfiehlt sich die Installation eines separaten Stromkreisweiges für jede Wechselstrom-Elektroschnur als Redundanz im Fall des Ausfalls eines Stromkreises.
MISE EN GARDE	Utilisez un circuit de dérivation différent pour chaque cordon d'alimentation C.A. Ainsi, il y aura un circuit redondant en cas de panne d'un des circuits.
PRECAUCIÓN	Use un circuito derivado separado para cada cordón de alimentación de CA, con lo que se proporcionará redundancia en caso de que uno de los circuitos falle.

CAUTION	Ensure that the device does not overload the power circuits, wiring, and over-current protection. To determine the possibility of overloading the supply circuits, add the ampere (amp) ratings of all devices installed on the same circuit as the device. Compare this total with the rating limit for the circuit. The maximum ampere ratings are usually printed on the devices near the input power connectors.
VORSICHT	Stromkreise, Verdrahtung und Überlastschutz dürfen nicht durch das Gerät überbelastet werden. Addieren Sie die Nennstromleistung (in Ampere) aller Geräte, die am selben Stromkreis wie das Gerät installiert sind. Somit können Sie feststellen, ob die Gefahr einer Überbelastung der Versorgungsstromkreise vorliegt. Vergleichen Sie diese Summe mit der Nennstromgrenze des Stromkreises. Die Höchstnennströme (in Ampere) stehen normalerweise auf der Geräterückseite neben den Eingangsstromanschlüssen.
MISE EN GARDE	Assurez-vous que le dispositif ne risque pas de surcharger les circuits d'alimentation, le câblage et la protection de surintensité. Pour déterminer le risque de surcharge des circuits d'alimentation, additionnez l'intensité nominale (ampères) de tous les dispositifs installés sur le même circuit que le dispositif en question. Comparez alors ce total avec la limite de charge du circuit. L'intensité nominale maximum en ampères est généralement imprimée sur chaque dispositif près des connecteurs d'entrée d'alimentation.
PRECAUCIÓN	Verifique que el instrumento no sobrecargue los circuitos de corriente, el cableado y la protección para sobrecargas. Para determinar la posibilidad de sobrecarga en los circuitos de suministros, añada las capacidades nominales de corriente (amp) de todos los instrumentos instalados en el mismo circuito que el instrumento. Compare esta suma con el límite nominal para el circuito. Las capacidades nominales de corriente máximas están generalmente impresas en los instrumentos, cerca de los conectores de corriente de entrada.

CAUTION	Use the erase startup-config command only for new systems. If you enter this command on a system you have already configured, the command erases the configuration. If you accidentally do erase the configuration on a configured system, enter the write memory command to save the running configuration to the startupconfig file.
VORSICHT	Verwenden Sie den Befehl "Erase startup-config" (Löschen Startup-Konfig) nur für neue Systeme. Wenn Sie diesen Befehl in ein bereits konfiguriertes System eingeben, löscht der Befehl die Konfiguration. Falls Sie aus Versehen die Konfiguration eines bereits konfigurierten Systems löschen, geben Sie den Befehl "Write Memory" (Speicher schreiben) ein, um die laufende Konfiguration in der Startup-Konfig-Datei zu speichern.
MISE EN GARDE	N'utilisez la commande erase startup-config que pour les nouveaux systèmes. Si vous entrez cette commande sur un système que vous avez déjà configuré, elle efface la configuration. Si vous effacez la configuration par accident sur un système configuré, entrez la commande write memory pour enregistrer la configuration actuelle dans le fichier startup-config.
PRECAUCIÓN	Use el comando erase startup-config (borrar configuración de inicio) para sistemas nuevos solamente. Si usted introduce este comando en un sistema que ya ha configurado, el comando borrará la configuración. Si usted borra accidentalmente la configuración en un sistema ya configurado, introduzca el comando write memory (escribir memoria) para guardar la configuración en ejecución en el archivo startupconfig.

CAUTION	Never leave tools inside the chassis.
VORSICHT	Lassen Sie keine Werkzeuge im Chassis zurück.
MISE EN GARDE	Ne laissez jamais d'outils à l'intérieur du châssis.
PRECAUCIÓN	No deje nunca herramientas en el interior del chasis.

CAUTION	Changes or modifications made to this device that are not expressly approved by the party responsible for compliance could void the user's authority to operate the equipment.
VORSICHT	Falls dieses Gerät verändert oder modifiziert wird, ohne die ausdrückliche Genehmigung der für die Einhaltung der Anforderungen verantwortlichen Partei einzuholen, kann dem Benutzer der weitere Betrieb des Gerätes untersagt werden.
MISE EN GARDE	Les éventuelles modifications apportées à cet équipement sans avoir été expressément approuvées par la partie responsable d'en évaluer la conformité sont susceptibles d'annuler le droit de l'utilisateur à utiliser cet équipement.
PRECAUCIÓN	Si se realizan cambios o modificaciones en este dispositivo sin la autorización expresa de la parte responsable del cumplimiento de las normas, la licencia del usuario para operar este equipo puede quedar anulada.

CAUTION	Make sure the power supply is properly inserted in the slot. Never insert the power supply upside down.
VORSICHT	Das Netzteil muss ordnungsgemäß im Steckplatz installiert sein. Das Netzteil darf auf keinen Fall umgekehrt in den Steckplatz gesteckt werden.
MISE EN GARDE	Assurez-vous que le bloc d'alimentation est correctement inséré dans l'emplacement. N'insérez jamais le bloc d'alimentation à l'envers.
PRECAUCIÓN	Verifique que el suministro de energía esté bien insertado en la ranura. No inserte nunca el suministro de energía en posición invertida.

C Danger

CAUTION	Danger of explosion if battery is incorrectly replaced. Replace only with the same or equivalent type recommended by the manufacturer. Dispose of used batteries according to the manufacturer's instructions.
VORSICHT	Explosionsgefahr bei unsachgemäßem Austausch der Batterie. Ersatz nur durch den selben oder einen vom Hersteller empfohlenen gleichwertigen Typ. Entsorgung gebrauchter Batterien nach Angaben des Herstellers.
MISE EN GARDE	Risque d'explosion avec l'échange inadéquat de la batterie. Remplacement seulement par le même ou un type équivalent recommandé par le producteur. L'évacuation des batteries usagées conformément à des indications du fabricant.
PRECAUCIÓN	Peligro de explosión si la batería se sustituye incorrectamente. Sustituya solamente por el mismo o tipo equivalente recomendado por el fabricante. Disponga las baterías usadas según las instrucciones del fabricante.

Danger

A danger calls your attention to a possible hazard that can cause injury or death. The following are the dangers used in this manual.

Gefahr weist auf eine mögliche Gefährdung hin, die zu Verletzungen oder Tod führen können. Sie finden die folgenden Warnhinweise in diesem Handbuch.

Un danger attire votre attention sur un risque possible de blessure ou de décès. Ci-dessous, vous trouverez les dangers utilisés dans ce manuel.

Una advertencia le llama la atención sobre cualquier peligro posible que pueda ocasionar daños personales o la muerte. A continuación se dan las advertencias utilizadas en este manual.

DANGER	The procedures in this manual are for qualified service personnel.
GEFAHR	Die Verfahren in diesem Handbuch sind nur für qualifiziertes Wartungspersonal gedacht.
DANGER	Les procédures décrites dans ce manuel doivent être effectuées par le personnel de service qualifié uniquement.
PELIGRO	Los procedimientos de este manual se han hecho para personal de servicio cualificado.

DANGER	All fiber optic interfaces use Class 1 lasers.
GEFAHR	Alle Glasfaser-Schnittstellen verwenden Laser der Klasse 1.
DANGER	Toutes les interfaces en fibres optiques utilisent des lasers de classe 1.
PELIGRO	Todas las interfaces de fibra óptica utilizan láser de clase 1.

DANGER	Make sure the rack or cabinet housing the device is adequately secured to prevent it from becoming unstable or falling over.
GEFAHR	Stellen Sie sicher, dass das Gestell oder der Schrank für die Unterbringung des Geräts auf angemessene Weise gesichert ist, so dass das Gestell oder der Schrank nicht wackeln oder umfallen kann.
DANGER	Vérifiez que le bâti ou le support abritant le dispositif est bien fixé afin qu'il ne devienne pas instable ou qu'il ne risque pas de tomber.
PELIGRO	Verifique que el bastidor o armario que alberga el instrumento está asegurado correctamente para evitar que pueda hacerse inestable o que caiga.

DANGER	Disconnect the PDU power cords (C13-C14) from all power sources to completely remove power from the device.
GEFAHR	Ziehen Sie das Stromkabel aus allen Stromquellen, um sicherzustellen, dass dem Gerät kein Strom zugeführt wird.
DANGER	Débranchez le cordon d'alimentation de toutes les sources d'alimentation pour couper complètement l'alimentation du dispositif.
PELIGRO	Para desconectar completamente la corriente del instrumento, desconecte el cordón de corriente de todas las fuentes de corriente.

DANGER	Make sure that the power source circuits are properly grounded, then use the PDU power cords (C13-C14) supplied with the device to connect it to the power source.
GEFAHR	Stellen Sie sicher, dass die Stromkreise ordnungsgemäß geerdet sind. Benutzen Sie dann das mit dem Gerät gelieferte Stromkabel, um es an die Stromquelle anzuschließen.
DANGER	Vérifiez que les circuits de sources d'alimentation sont bien mis à la terre, puis utilisez le cordon d'alimentation fourni avec le dispositif pour le connecter à la source d'alimentation.
PELIGRO	Verifique que circuitos de la fuente de corriente están conectados a tierra correctamente; luego use el cordón de potencia suministrado con el instrumento para conectarlo a la fuente de corriente.

C Danger

DANGER	If the installation requires a different PDU power cords (C13-C14) than the one supplied with the device, make sure you use a PDU power cords (C13-C14) displaying the mark of the safety agency that defines the regulations for PDU power cords (C13-C14) in your country. The mark is your assurance that the PDU power cords (C13-C14) can be used safely with the device.
GEFAHR	Falls für die Installation ein anderes Stromkabel erforderlich ist (wenn das mit dem Gerät gelieferte Kabel nicht passt), müssen Sie sicherstellen, dass Sie ein Stromkabel mit dem Siegel einer Sicherheitsbehörde verwenden, die für die Zertifizierung von Stromkabeln in Ihrem Land zuständig ist. Das Siegel ist Ihre Garantie, dass das Stromkabel sicher mit Ihrem Gerät verwendet werden kann.
DANGER	Si l'installation nécessite un cordon d'alimentation autre que celui fourni avec le dispositif, assurez-vous d'utiliser un cordon d'alimentation portant la marque de l'organisation responsable de la sécurité qui définit les normes et réglementations pour les cordons d'alimentation dans votre pays. Cette marque vous assure que vous pouvez utiliser le cordon d'alimentation avec le dispositif en toute sécurité.
PELIGRO	Si la instalación requiere un cordón de corriente distinto al que se ha suministrado con el instrumento, verifique que usa un cordón de corriente que venga con la marca de la agencia de seguridad que defina las regulaciones para cordones de corriente en su país. Esta marca será su garantía de que el cordón de corriente puede ser utilizado con seguridad con el instrumento.

DANGER	Power supplies are hot swappable, which means they can be removed and replaced while the chassis is powered on and running. However, <i>Dell</i> recommends that you disconnect the power supply from the wall outlet before removing and replacing the supply. The device can be running while a power supply is being installed or removed, but the power supply itself should not be connected to a power source. Otherwise, you could be injured or the power supply or other parts of the device could be damaged.
GEFAHR	Netzteile können unter Strom stehend ausgetauscht werden. Allerdings empfiehlt <i>Dell</i> , dass Sie das Netzteil vom Netzstrom abtrennen, bevor Sie das Netzteil anschließen oder abtrennen. Das Gerät kann während des Anschließens oder Abnehmens des Netzteils laufen. Nur das Netzteil sollte nicht an eine Stromquelle angeschlossen sein. Ansonsten können Sie verletzt oder das Netzteil bzw. andere Geräteteile beschädigt werden.
DANGER	Les blocs d'alimentation peuvent être changés à chaud. Cependant, <i>Dell</i> vous conseille de débrancher le bloc d'alimentation de l'alimentation C.A. avant d'installer ou d'enlever le bloc d'alimentation. Le dispositif peut être en cours de fonctionnement pendant que vous installez ou enlevez un bloc d'alimentation, mais le bloc d'alimentation lui-même ne doit pas être connecté à une source d'alimentation. Sinon, vous risquez d'être blessé ou le bloc d'alimentation ou d'autres pièces du dispositif risquent d'être endommagés.
PELIGRO	Los suministros de corriente pueden intercambiarse sin necesidad de ajustes. No obstante, <i>Dell</i> recomienda que desconecte el suministro de corriente de la toma de corriente alterna antes de instalar o retirar el suministro. El instrumento puede estar activado cuando se esté instalando o retirando un suministro de corriente, pero el suministro de corriente en sí no deberá estar conectado a la fuente de corriente. De no hacerlo así, podría sufrir daños personales o el suministro de corriente u otras piezas podrían resultar dañadas.

DANGER	Before beginning the installation, refer to the precautions in “Power precautions” on page 12.
GEFAHR	Vor der Installation siehe Vorsichtsmaßnahmen unter “Power precautions” (Vorsichtsmaßnahmen in Bezug auf elektrische Ablagen) auf den Seiten page 12.
DANGER	Avant de commencer l'installation, consultez les précautions décrites dans “Power precautions” (Précautions quant à l'alimentation), pages page 12.
PELIGRO	Antes de comenzar la instalación, consulte las precauciones en la sección “Power precautions” (Precauciones sobre corriente) que se encuentra en las páginas page 12.

DANGER	For safety reasons, the ESD wrist strap should contain a series 1 meg ohm resistor.
GEFAHR	Aus Sicherheitsgründen sollte ein EGB-Armband zum Schutz von elektronischen gefährdeten Bauelementen mit einem 1 Megaohm-Reihenwiderstand ausgestattet sein.
DANGER	Pour des raisons de sécurité, la dragonne ESD doit contenir une résistance de série 1 méga ohm.
PELIGRO	Por razones de seguridad, la correa de muñeca ESD deberá contener un resistor en serie de 1 mega ohmio.

DANGER	Be careful not to accidentally insert your fingers into the fan tray while removing it from the chassis. The fan may still be spinning at a high speed.
GEFAHR	Die Finger dürfen nicht versehentlich in das Ventilatorblech gesteckt werden, wenn dieses vom Gehäuse abgenommen wird. Der Ventilator kann sich unter Umständen noch mit hoher Geschwindigkeit drehen.
DANGER	Faites attention de ne pas accidentellement insérer vos doigts dans le boîtier du ventilateur lorsque vous l'enlevez du châssis. Il est possible que le ventilateur tourne encore à grande vitesse.
PELIGRO	Procure no insertar los dedos accidentalmente en la bandeja del ventilador cuando esté desmontando el chasis. El ventilador podría estar girando a gran velocidad.

C Danger